

# Sestava štiritaktnega bencinskega Ottovega motorja

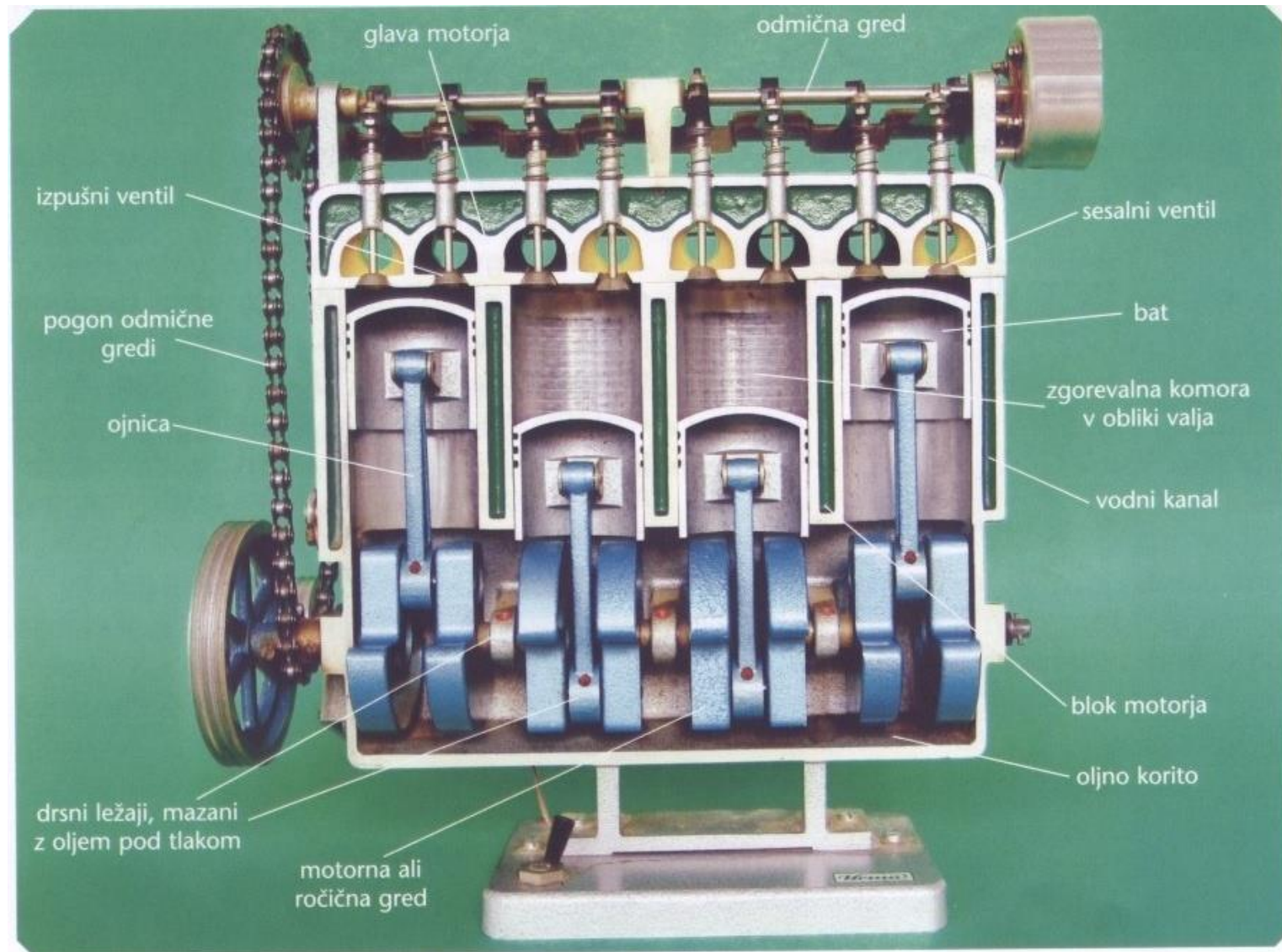

# Blok motorja

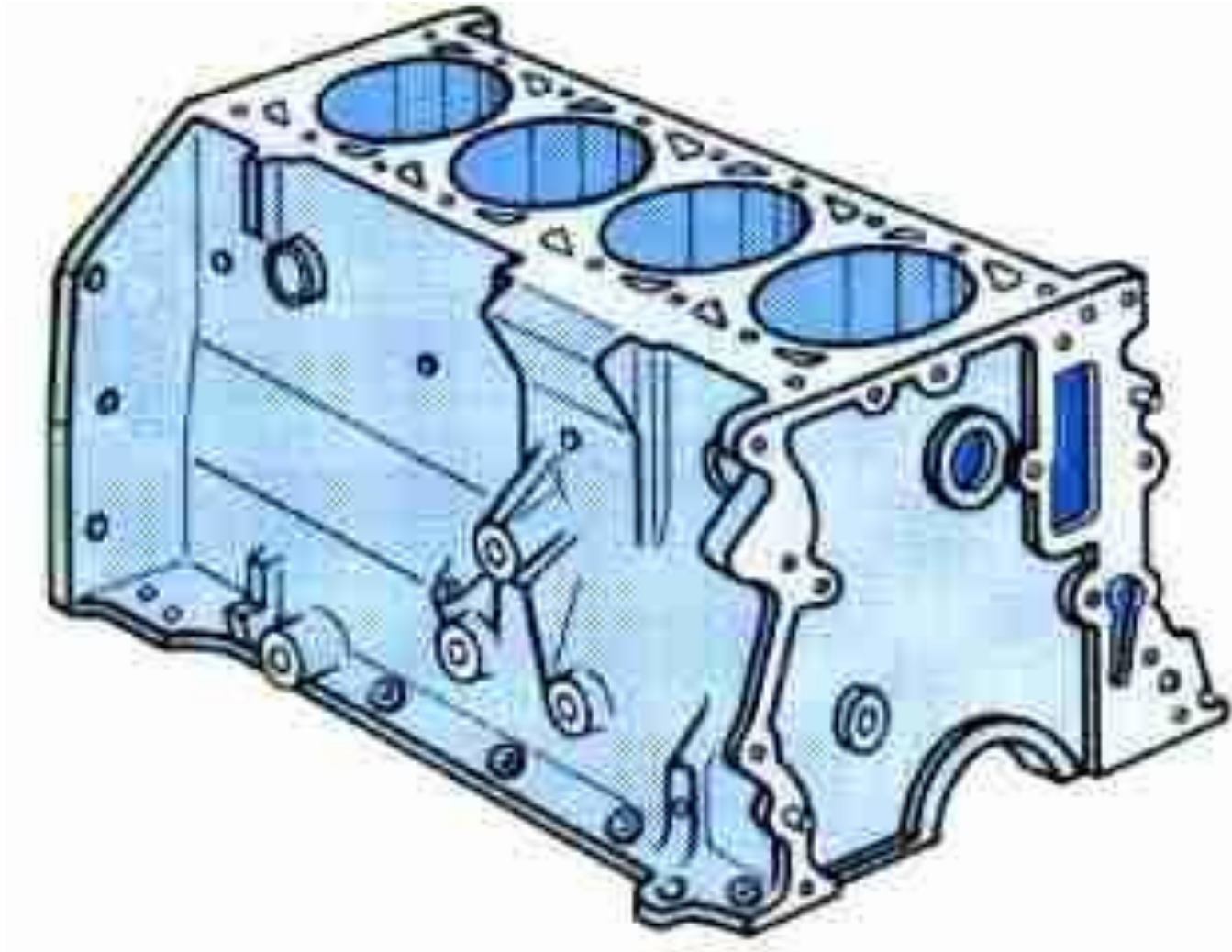

# Glava motorja

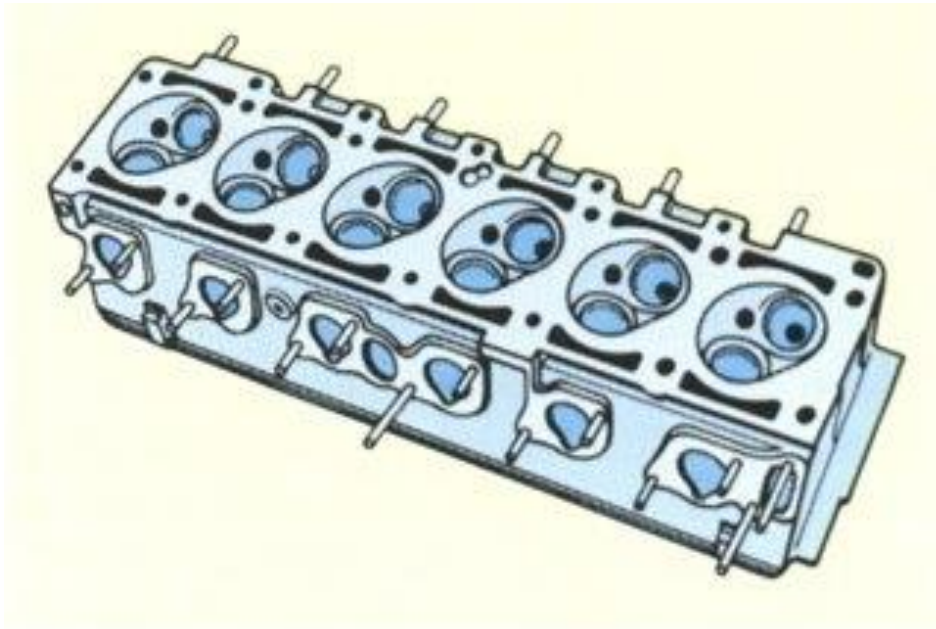

Slika 4: Tekočinsko hlajena glava motorja

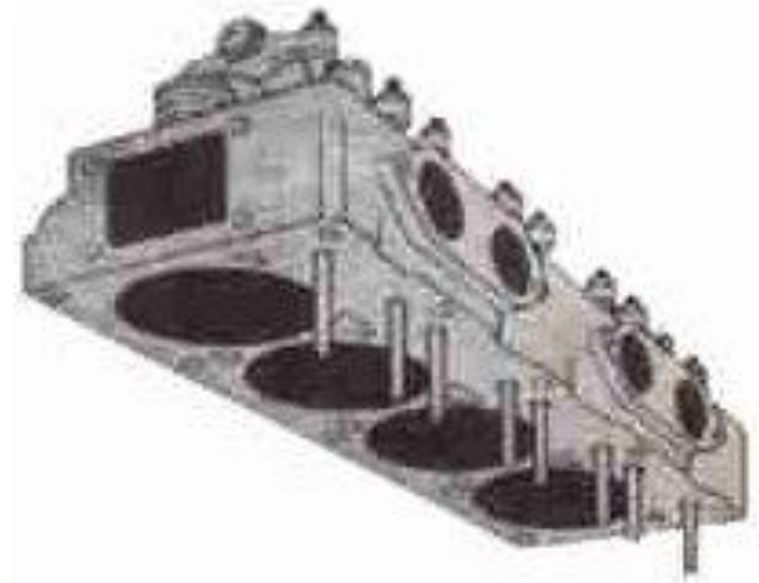

Slika 5: Glava motorja

# Oljno korito in tesnilo



Slika 6: Tesnilo

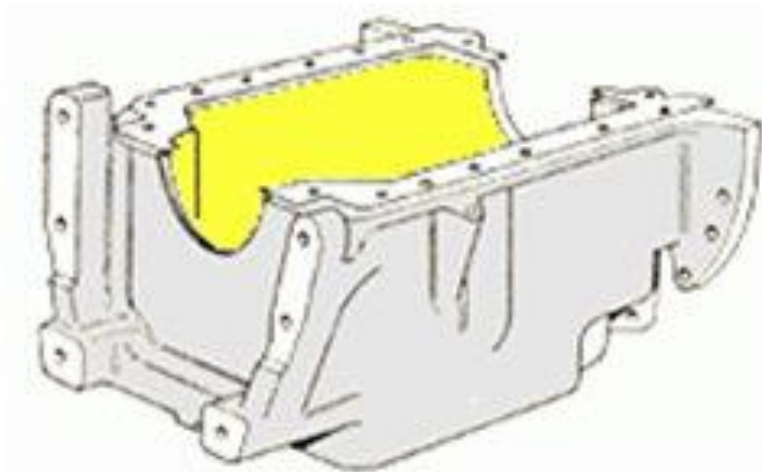

Slika 7 : primer za uporabo tesnilne paste (hermetik)

# Bat motorja



Slika 12: Bat

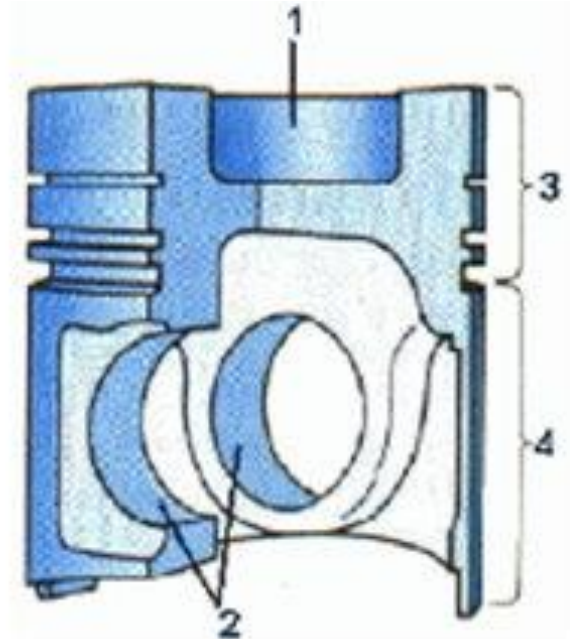

Slika 13: sestavni deli bata:

- 1 - zgorevalna vdolbina,
- 2 - pesto za batni sornik
- 3 - pas za batne obročke
- 4 - plašč bata

# Batni obročki

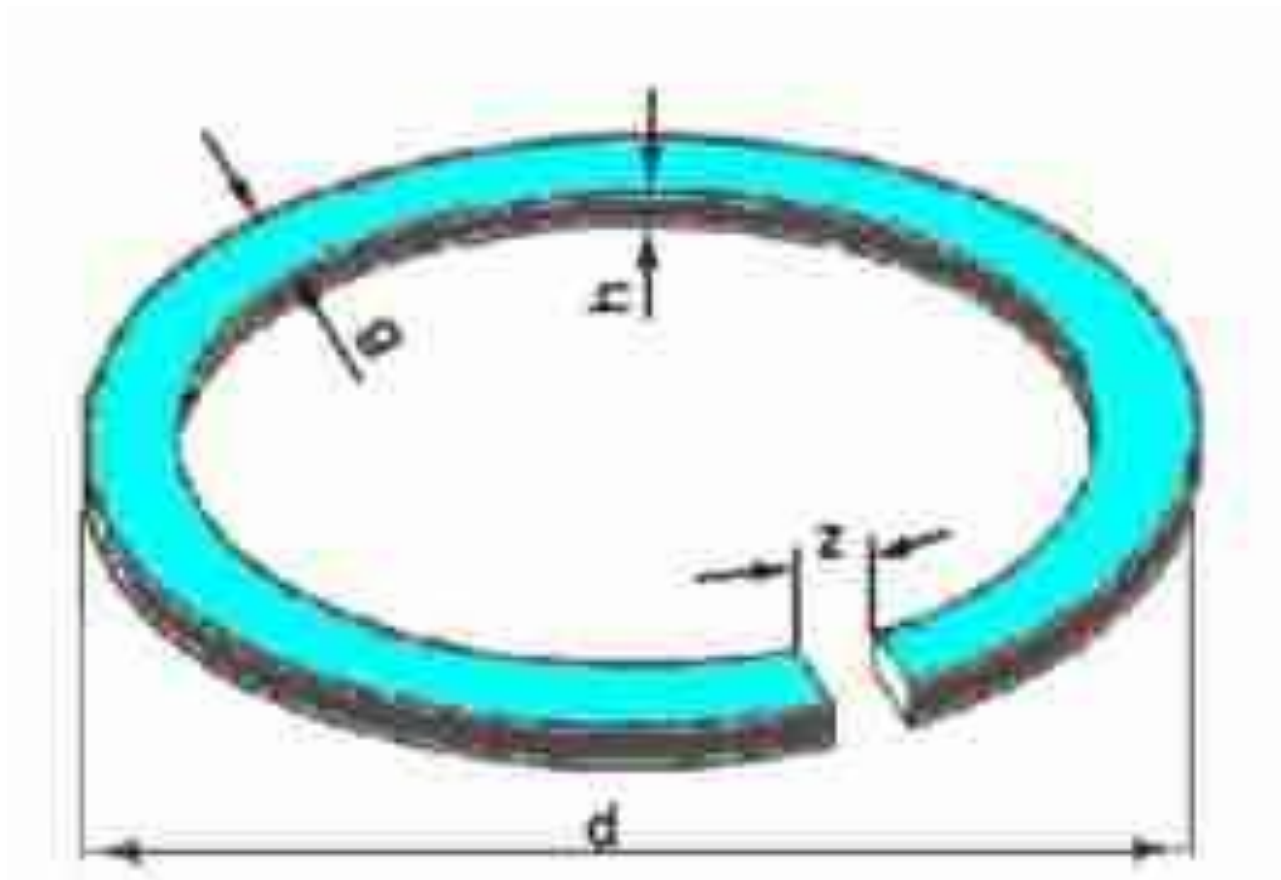

# Ojnica

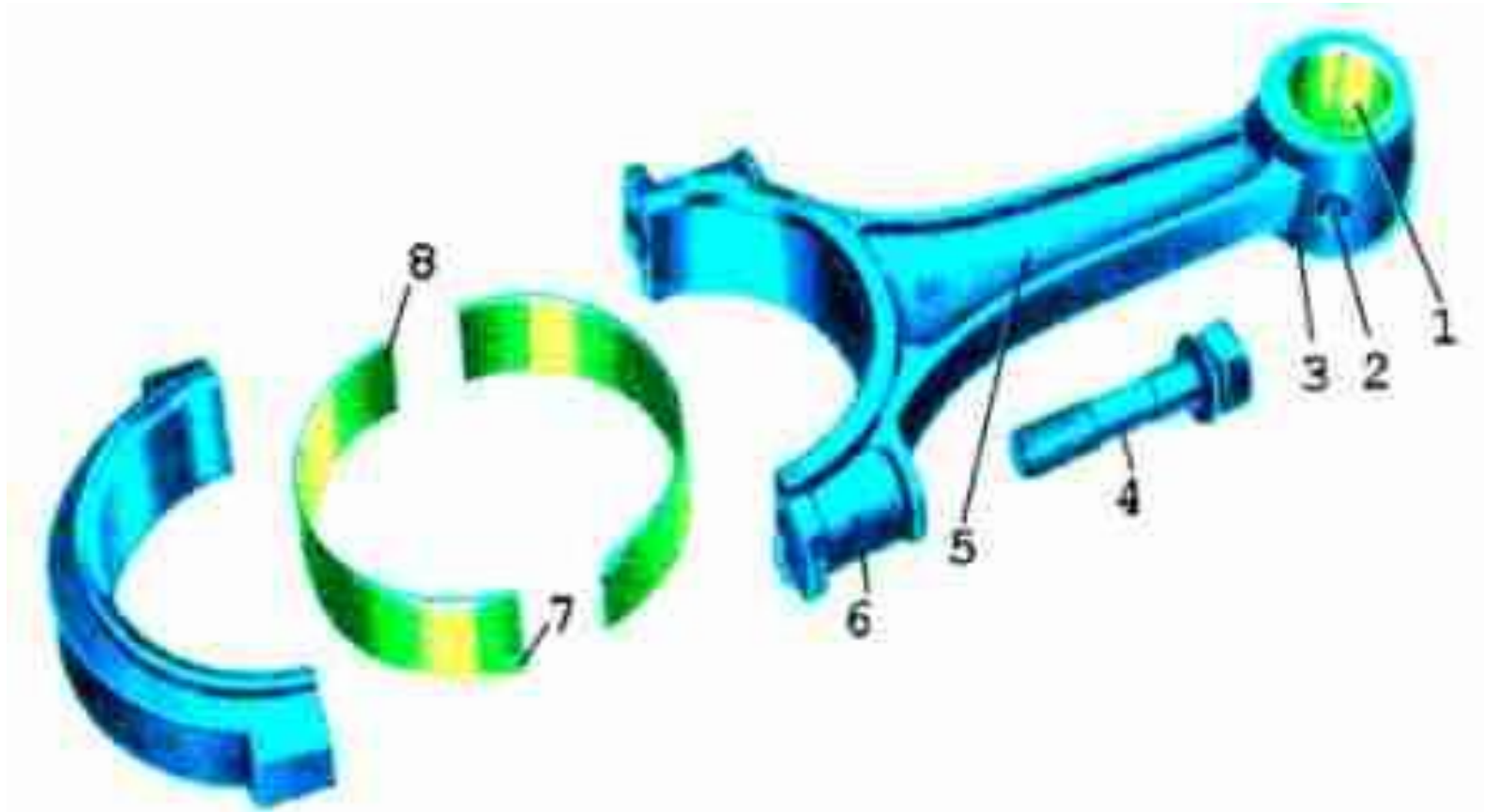

# Motorna ali ročična gred



# Zgorevalni prostor

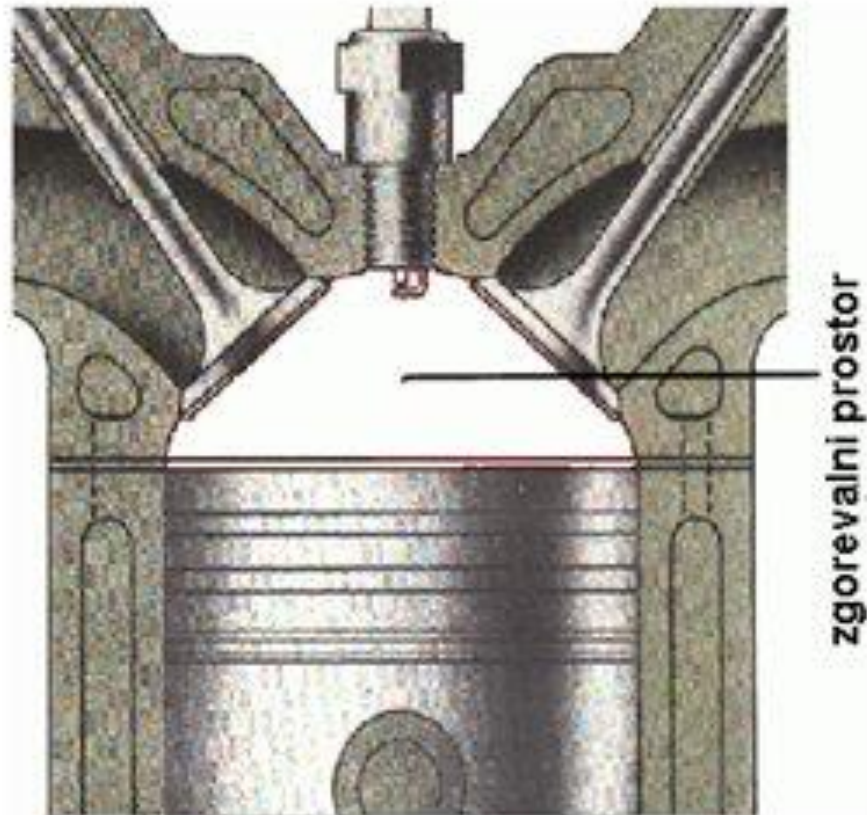

Slika 8: zaobljeni zgorevalni prostor

# Odmična gred



# Odmičná gred - prikaz

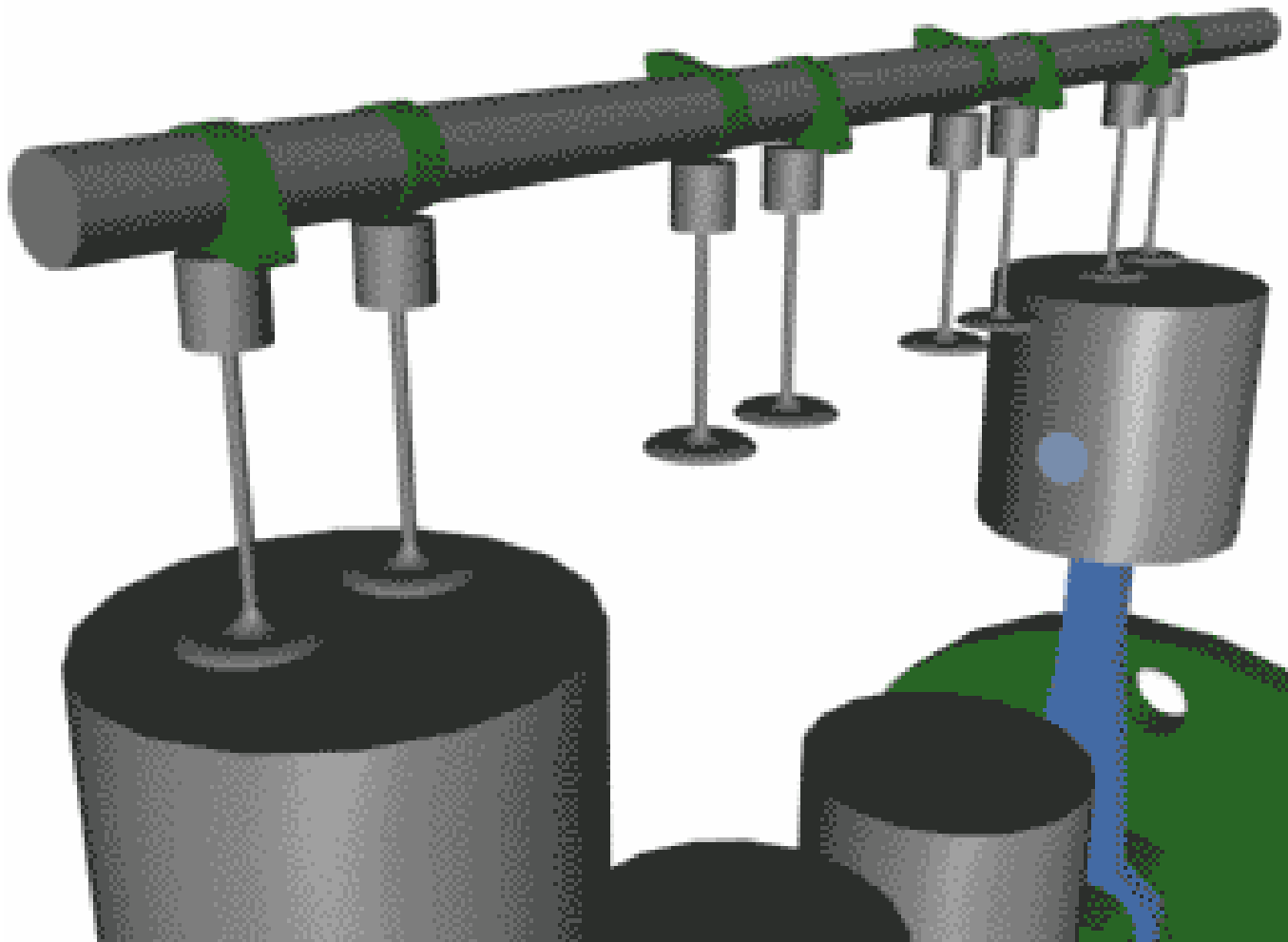

# Ventili (sesalni in izpušni)

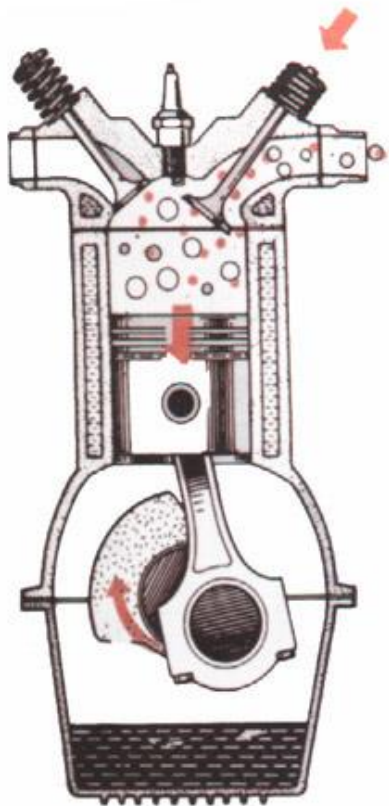

Air intake

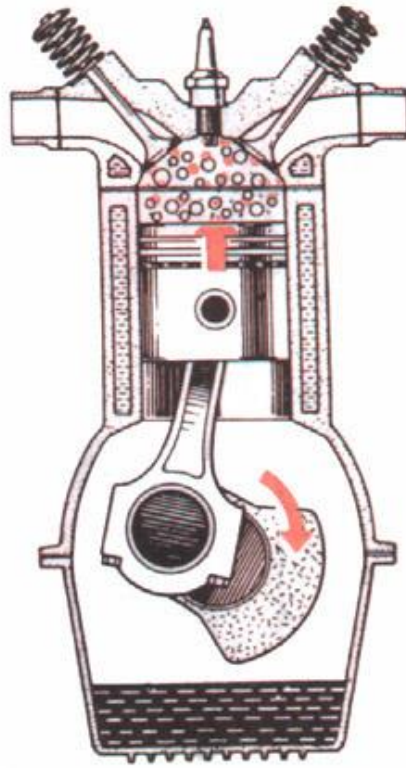

Compression

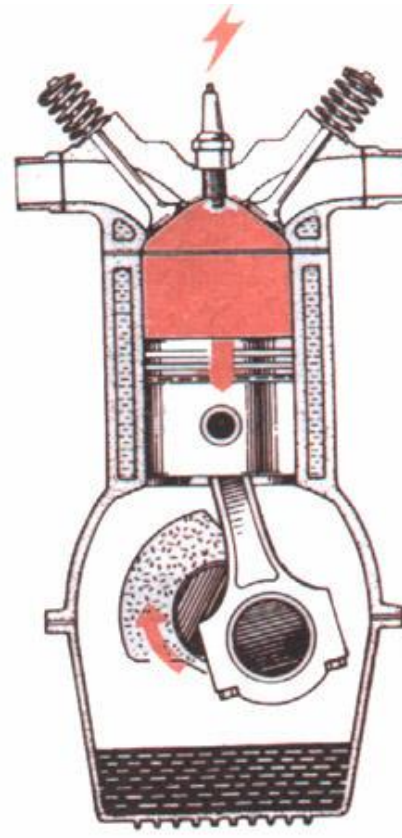

Combustion

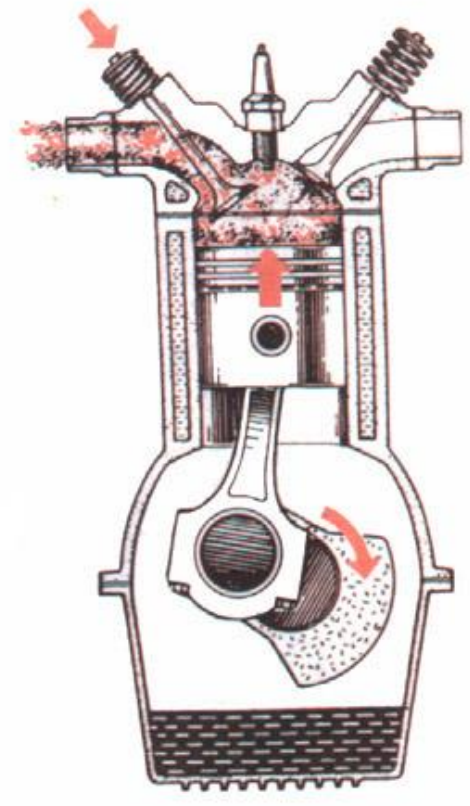

Exhaust Emission