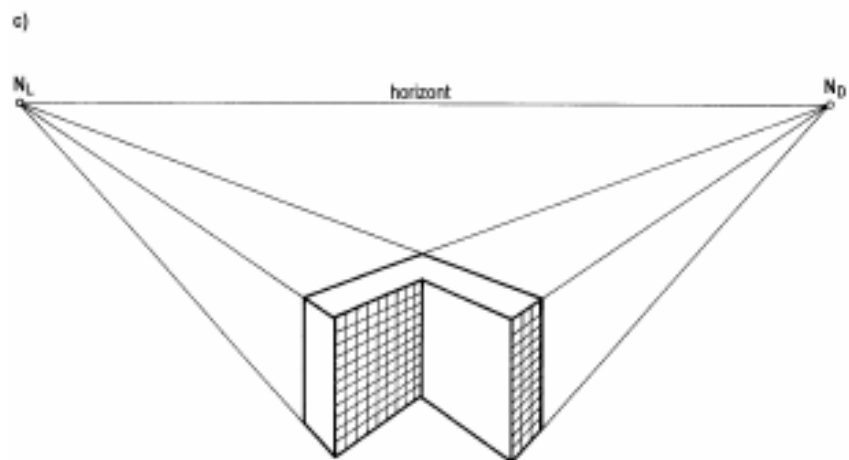
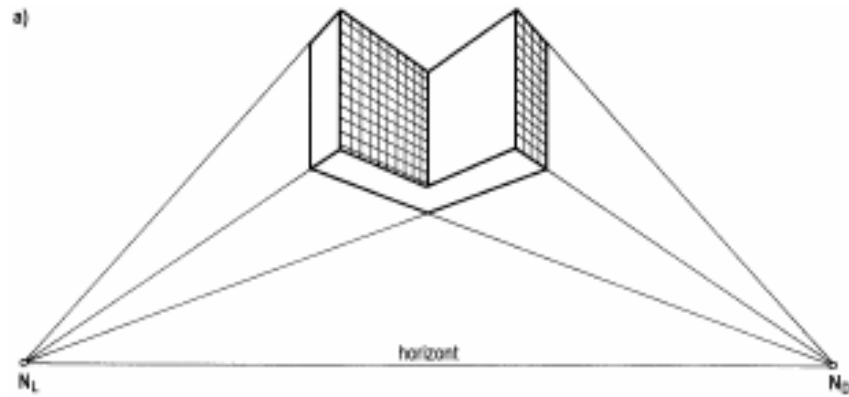
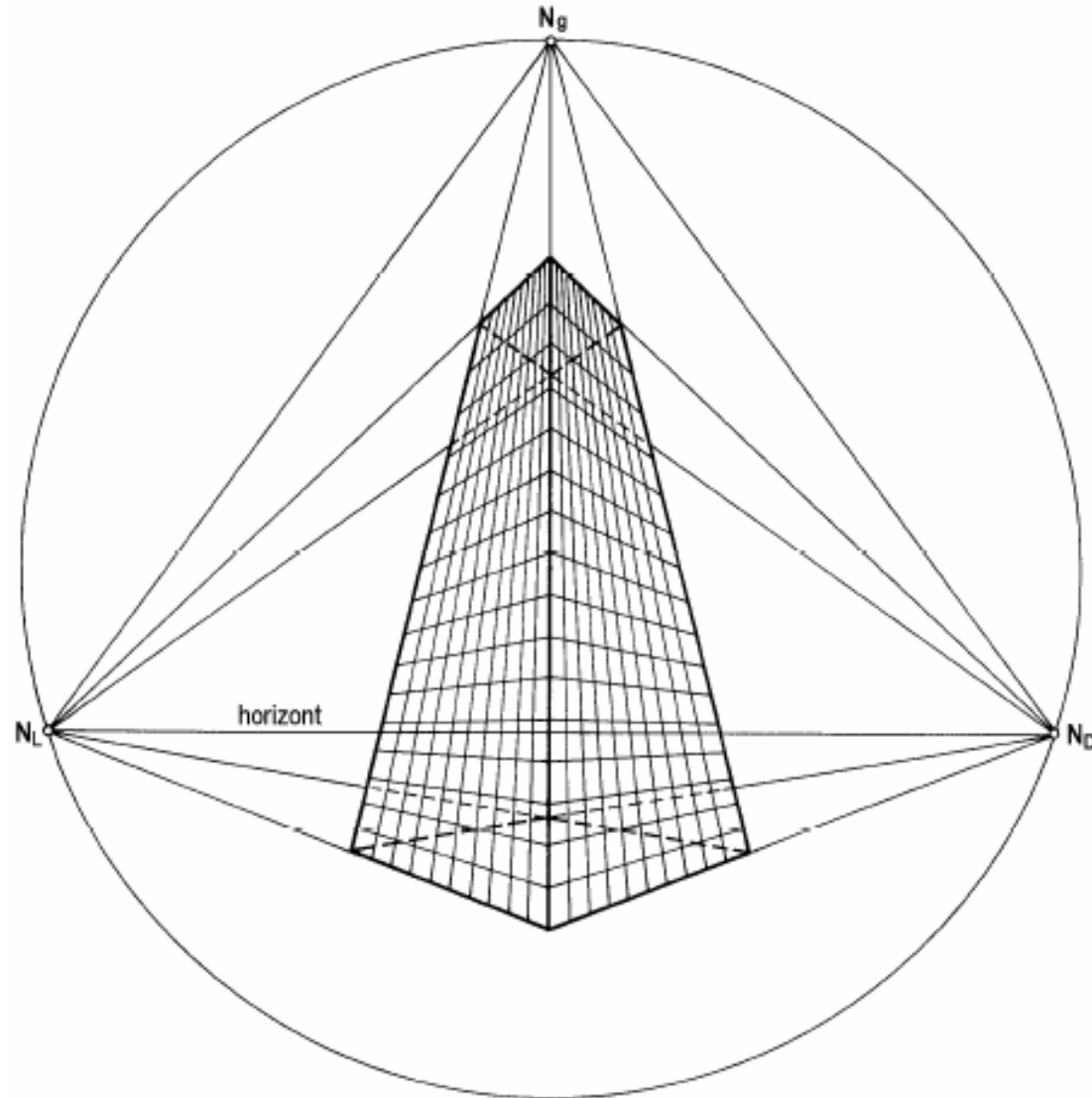


# Projekcije

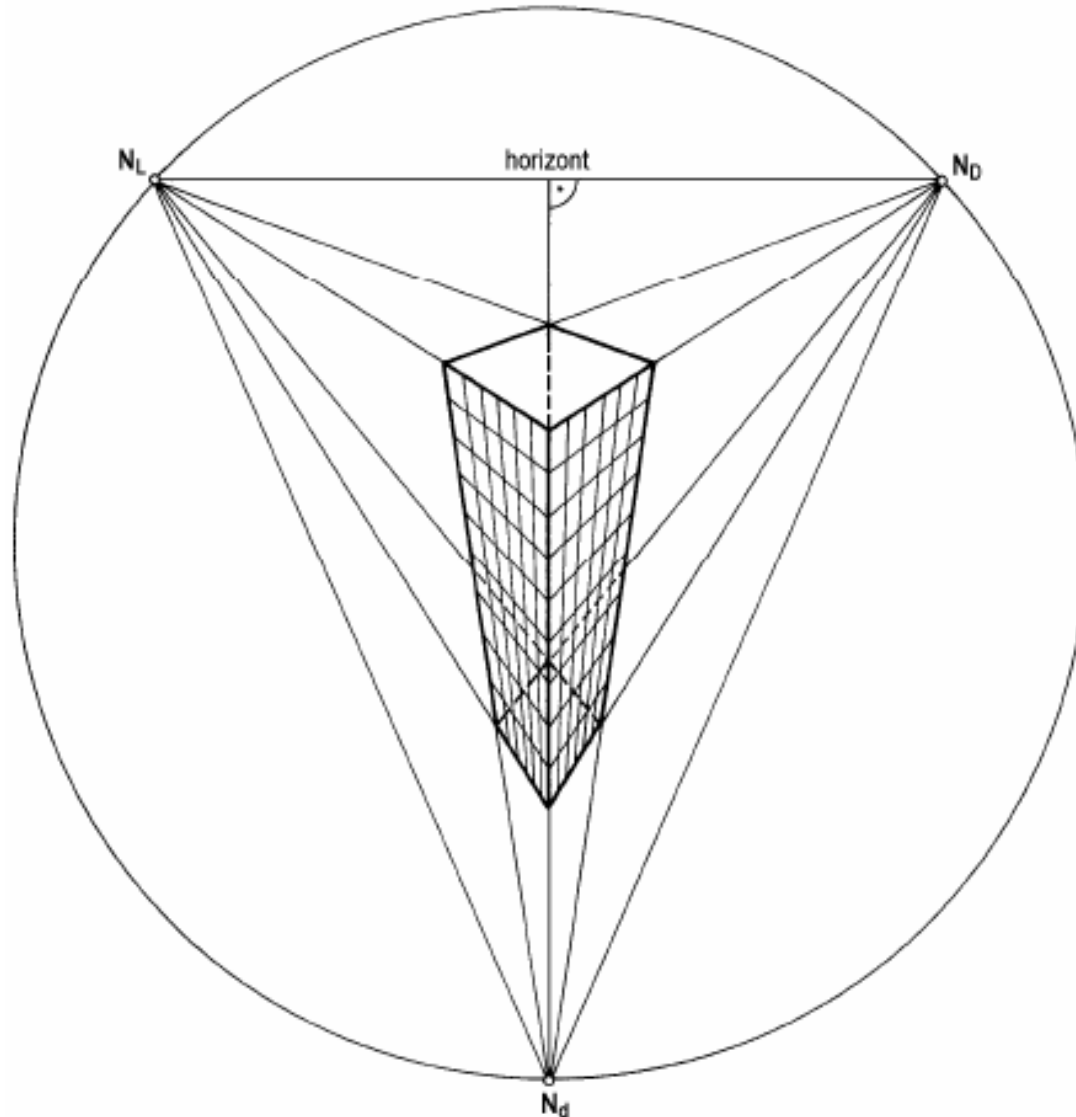
# Predmet v perspektivi



# Primer centralne projekcije s tremi žarišči (žabja perspektiva)



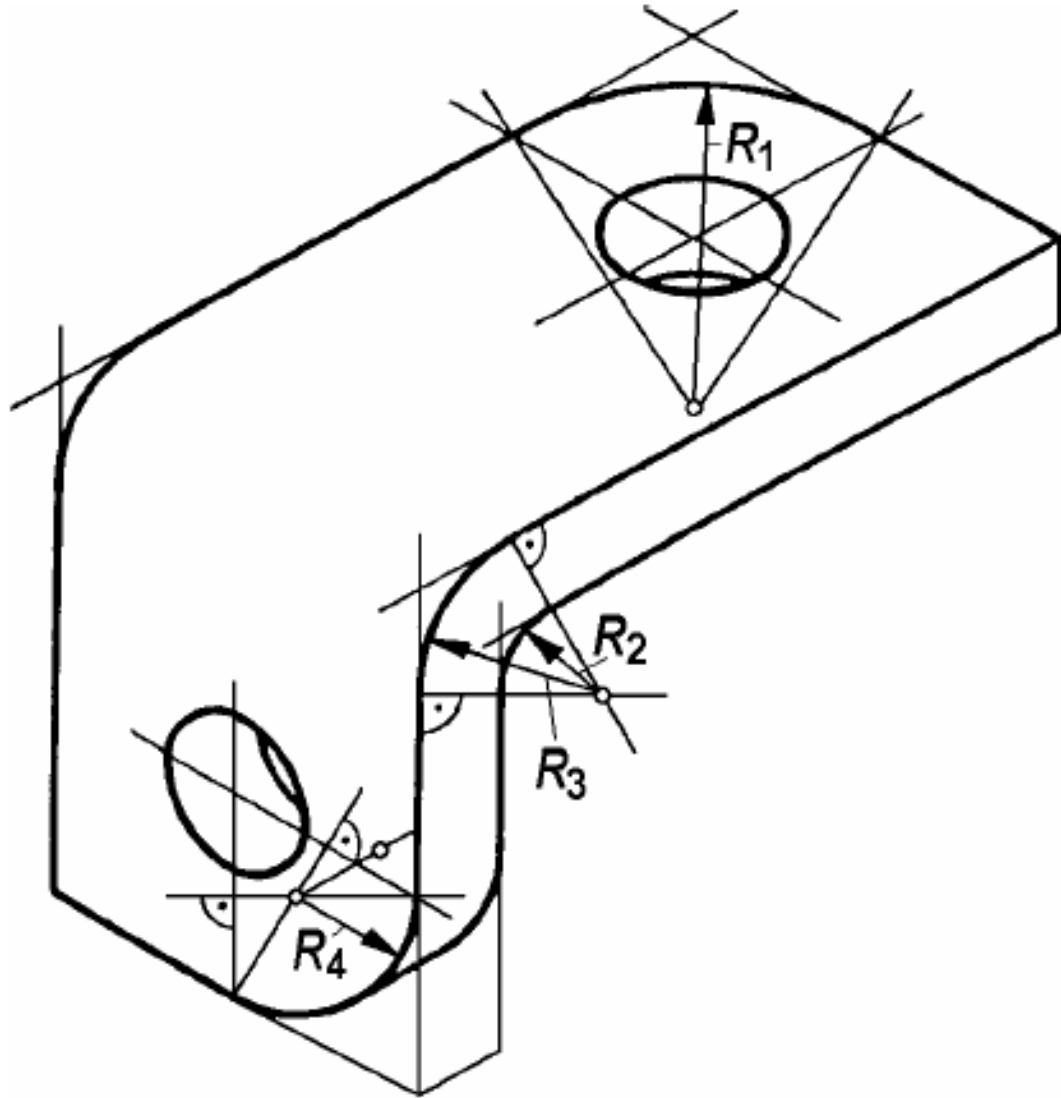
# Primer centralne projekcije z tremi žarišči (ptičja perspektiva)

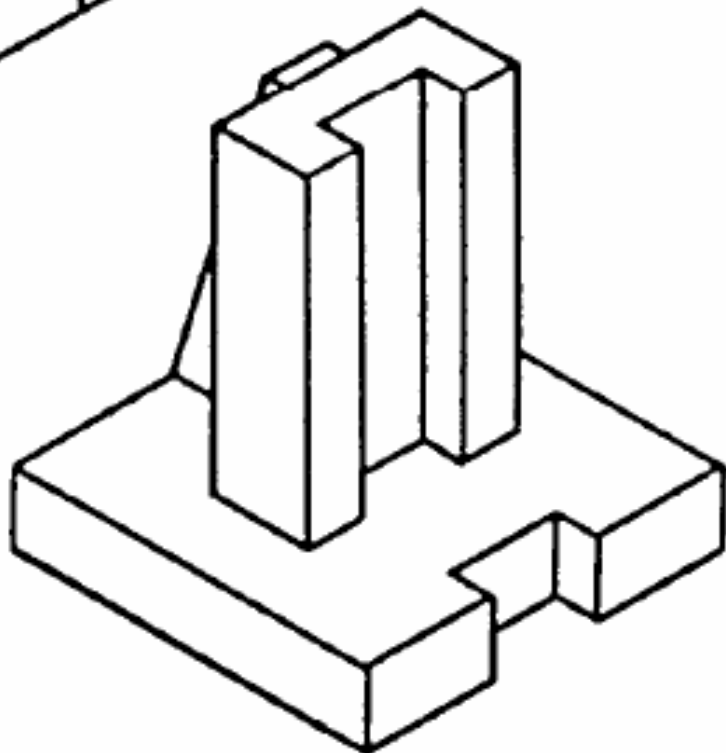
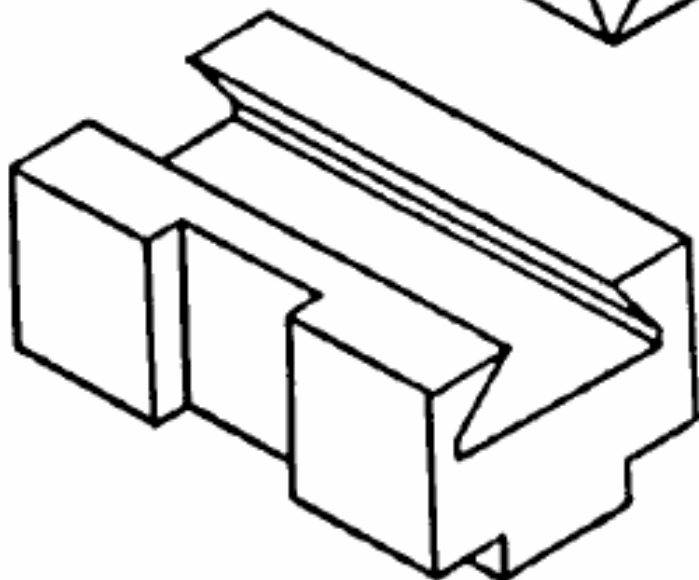
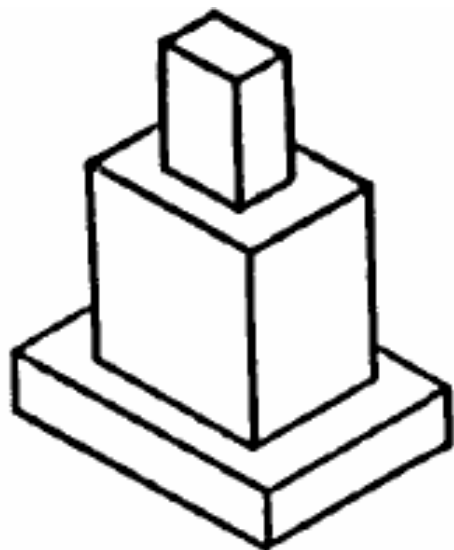
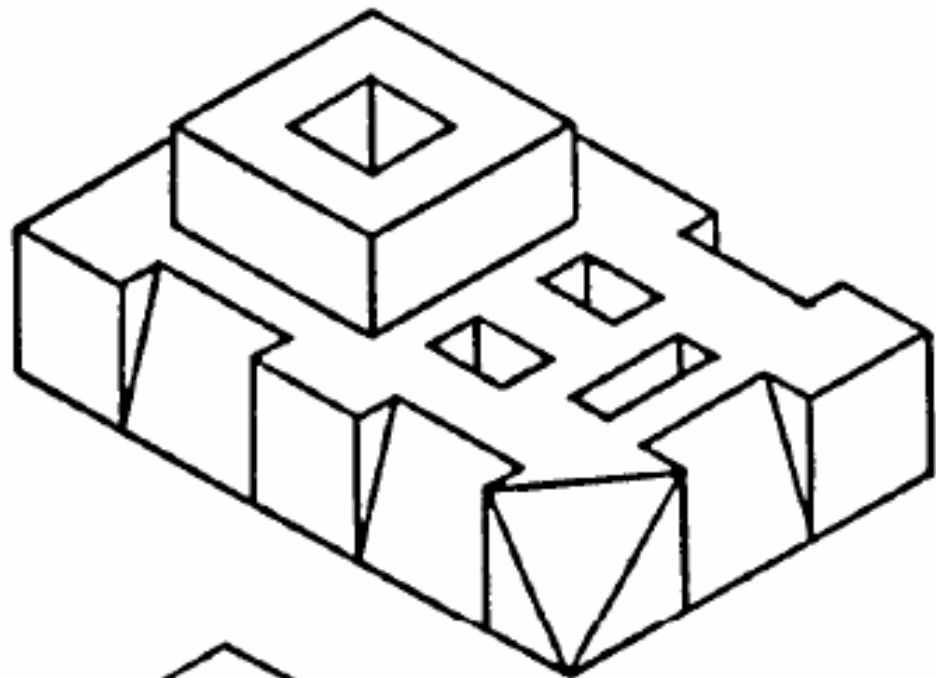


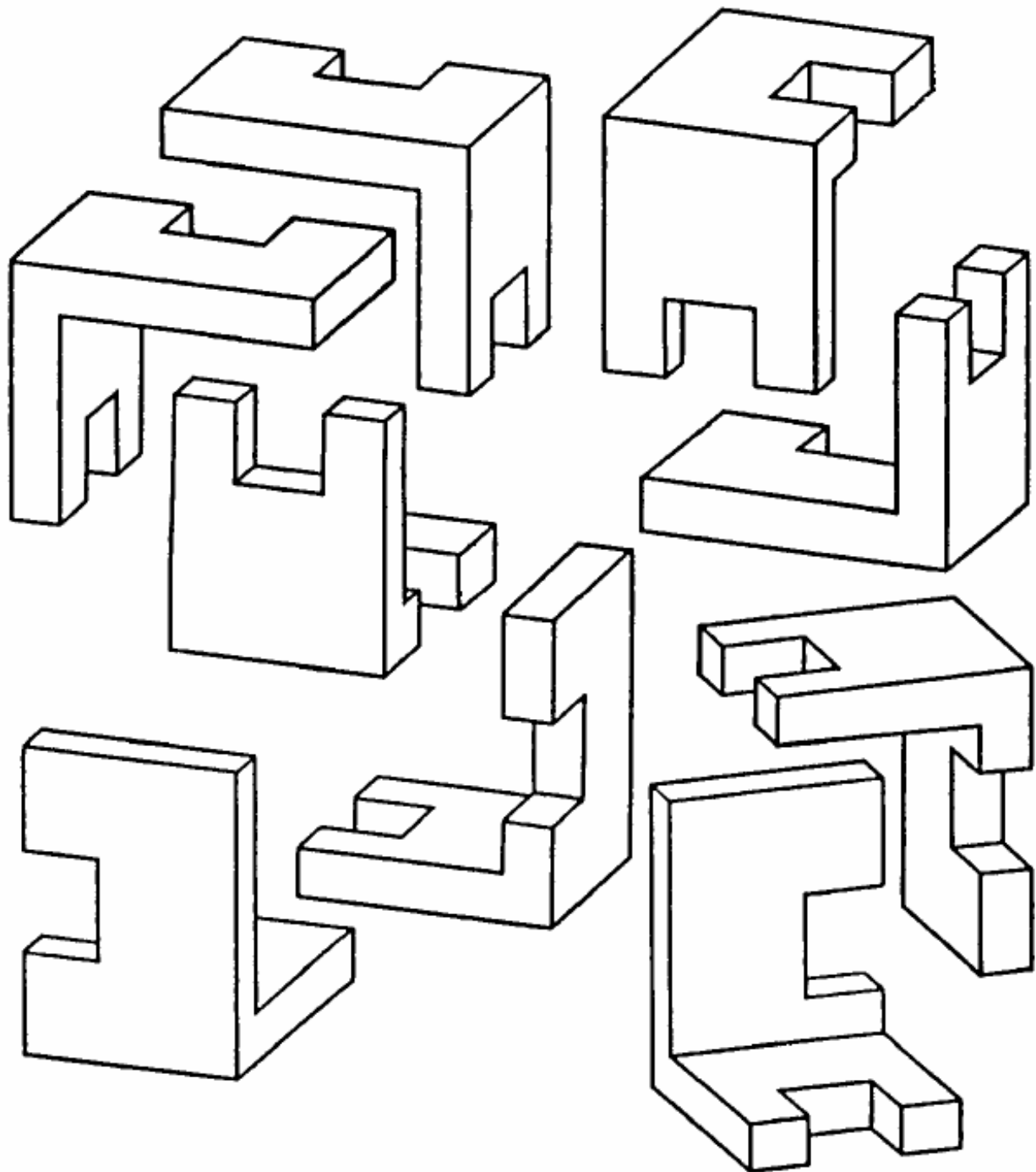
# Karakteristične izmere pri aksiometričnih projekcijah

|     |                        | Karakteristične izmere    |                 |          |   |                 |
|-----|------------------------|---------------------------|-----------------|----------|---|-----------------|
|     |                        | $\alpha$                  | $\beta$         | a        | b | c               |
| A   | Poševna aksonometrija  |                           |                 |          |   |                 |
| A.1 | Poševna projekcija     | $30^\circ \dots 40^\circ$ | $0^\circ$       | 1        | 1 | $1/2 \dots 2/3$ |
| A.2 | Frontalna projekcija   | $30^\circ \dots 40^\circ$ | $0^\circ$       | 1        | 1 |                 |
| B   | Ortogonalna projekcija |                           |                 |          |   |                 |
| B.1 | Izometrična projekcija | $30^\circ$                | $30^\circ$      | 1        | 1 | 1               |
| B.2 | Dimetrična projekcija  | $42^\circ$                | $7^\circ$       | 1        | 1 | $\frac{1}{2}$   |
| B3  | Trimetrična projekcija | $30^\circ \dots 45^\circ$ | $\neq 30^\circ$ | poljubno |   |                 |

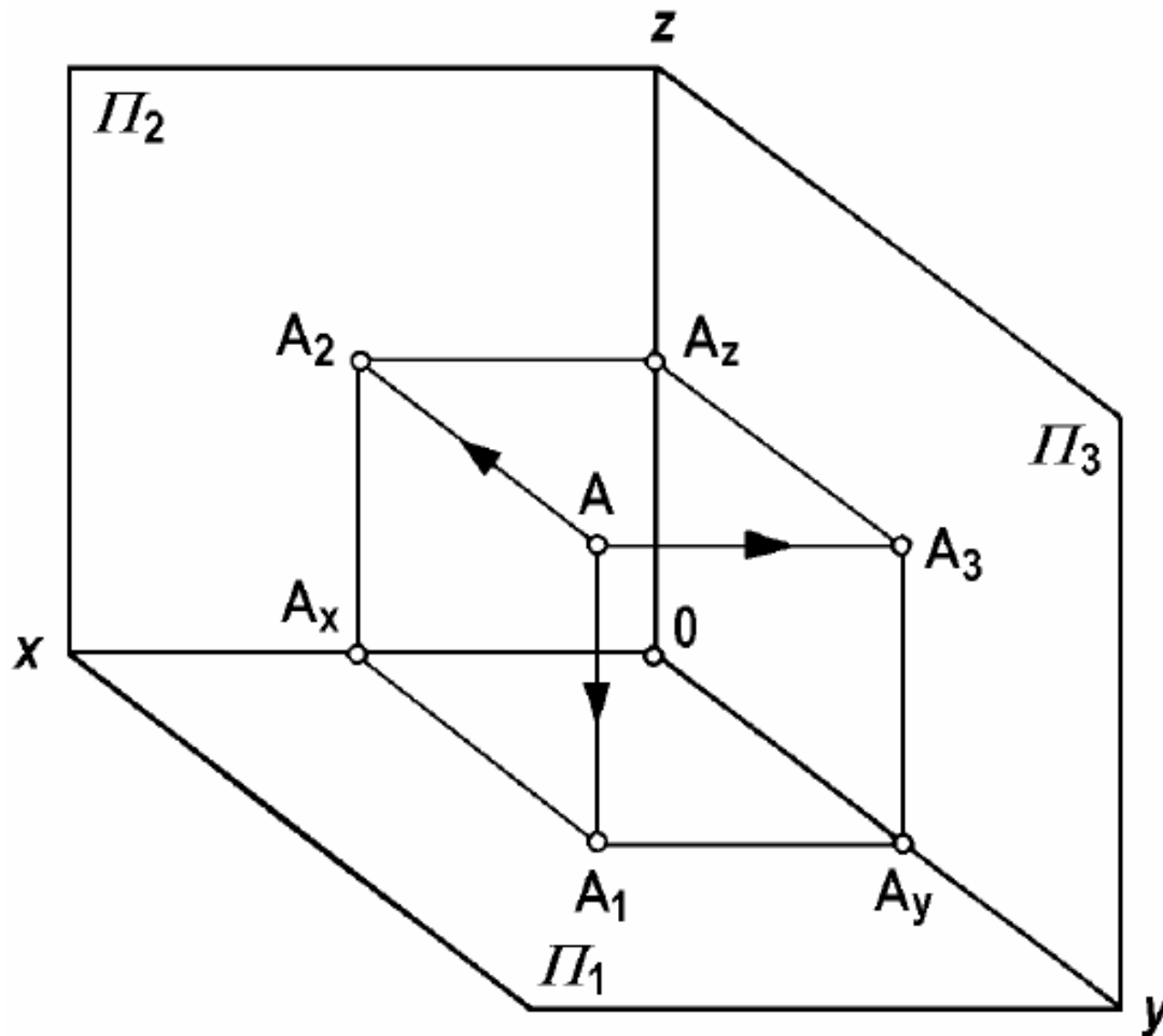
# Izometrična projekcija



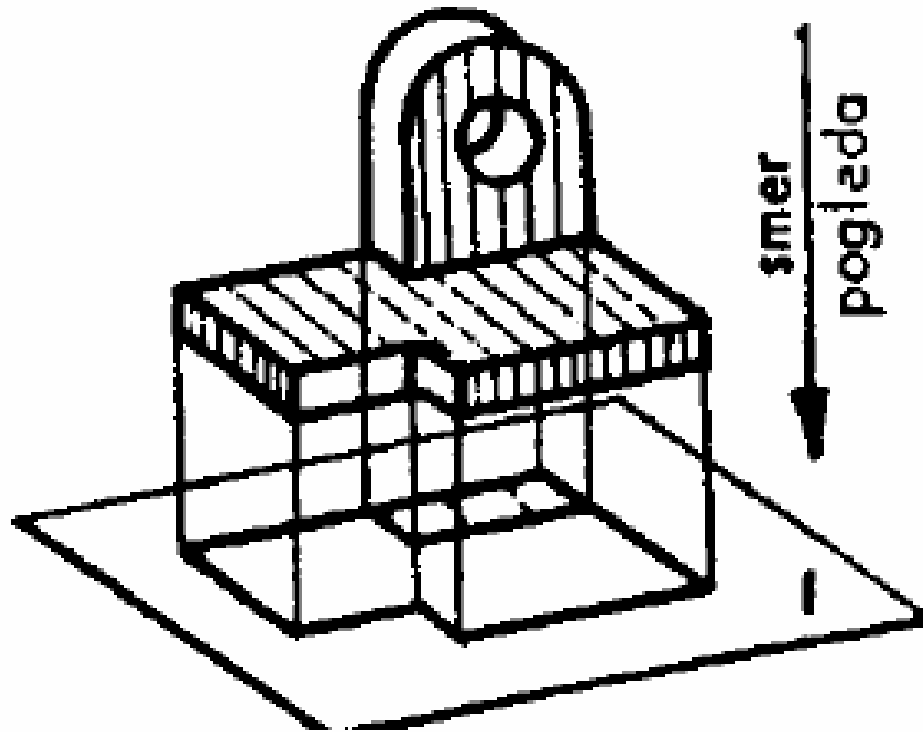




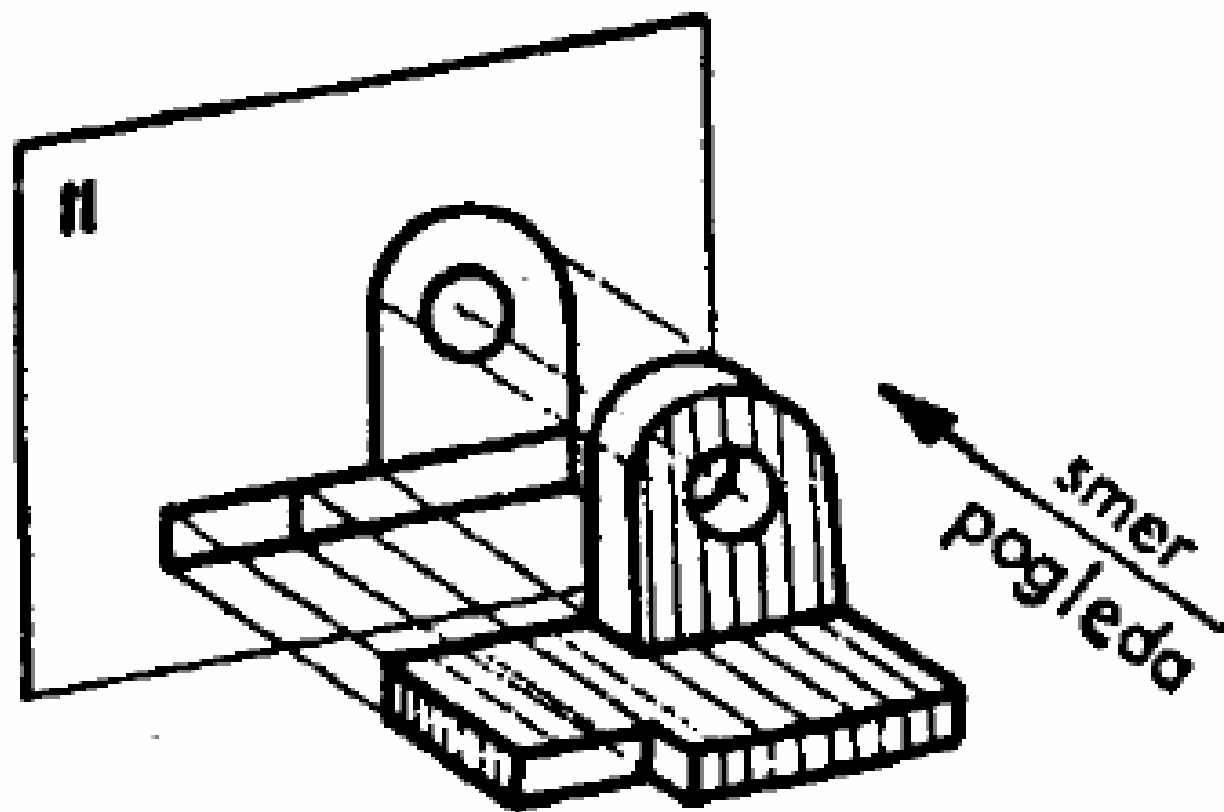
# Projiciranje v treh ravninah



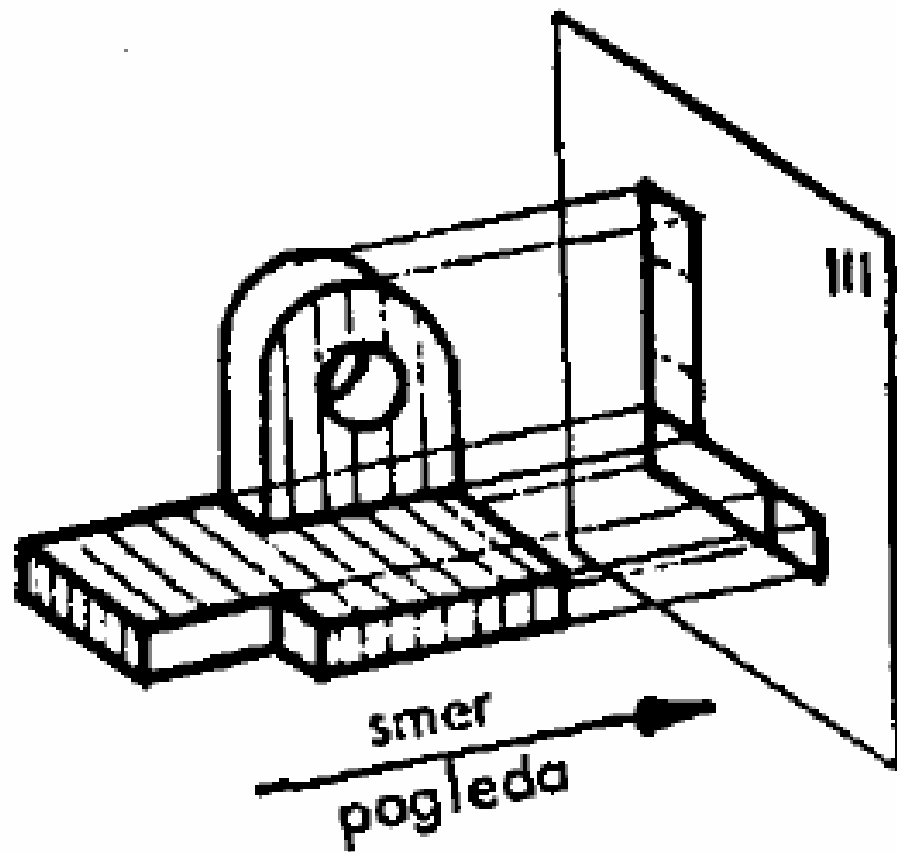
# Ortogonalno Mongeovo projiciranje



Tloris



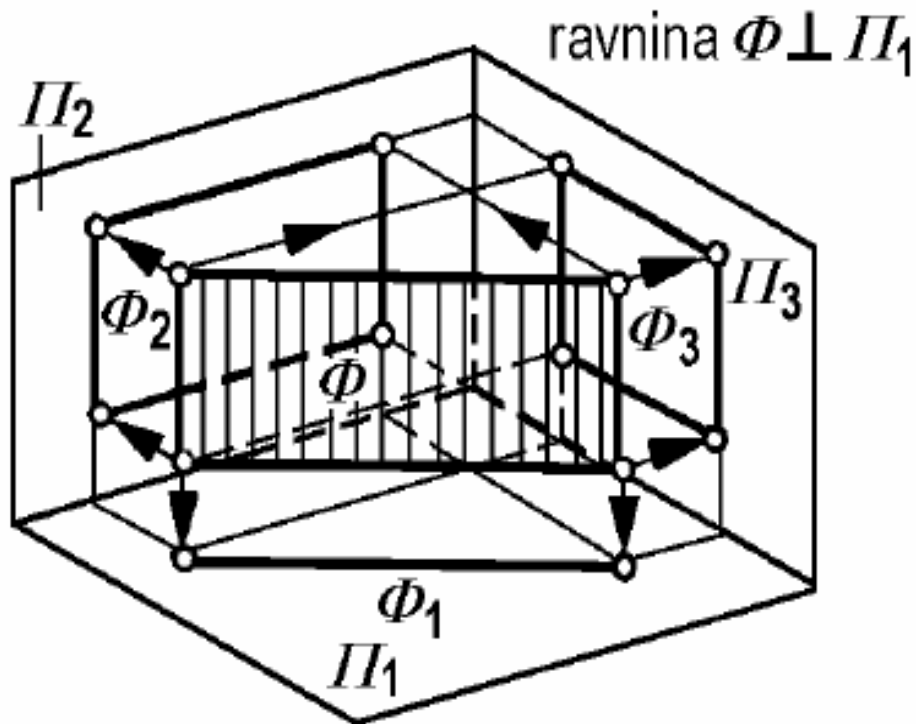
Naris



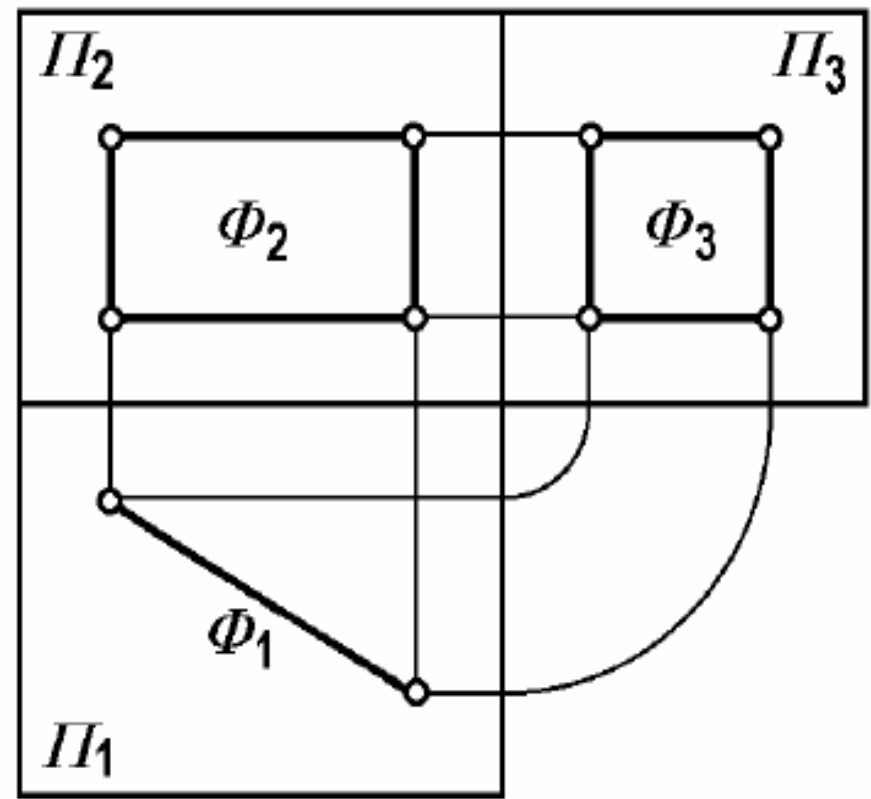
Stranski ris

# Ortogonalno projiciranje ravnine, ki je pravokotna na P1

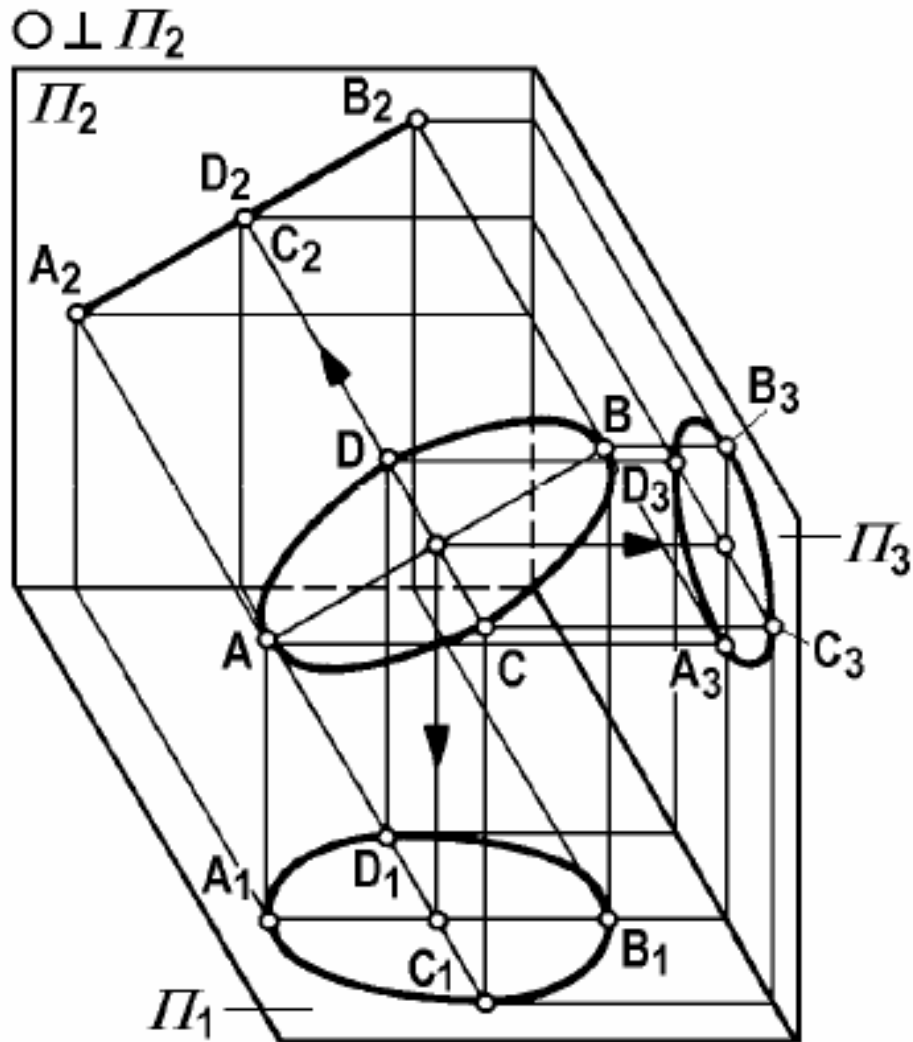
a)



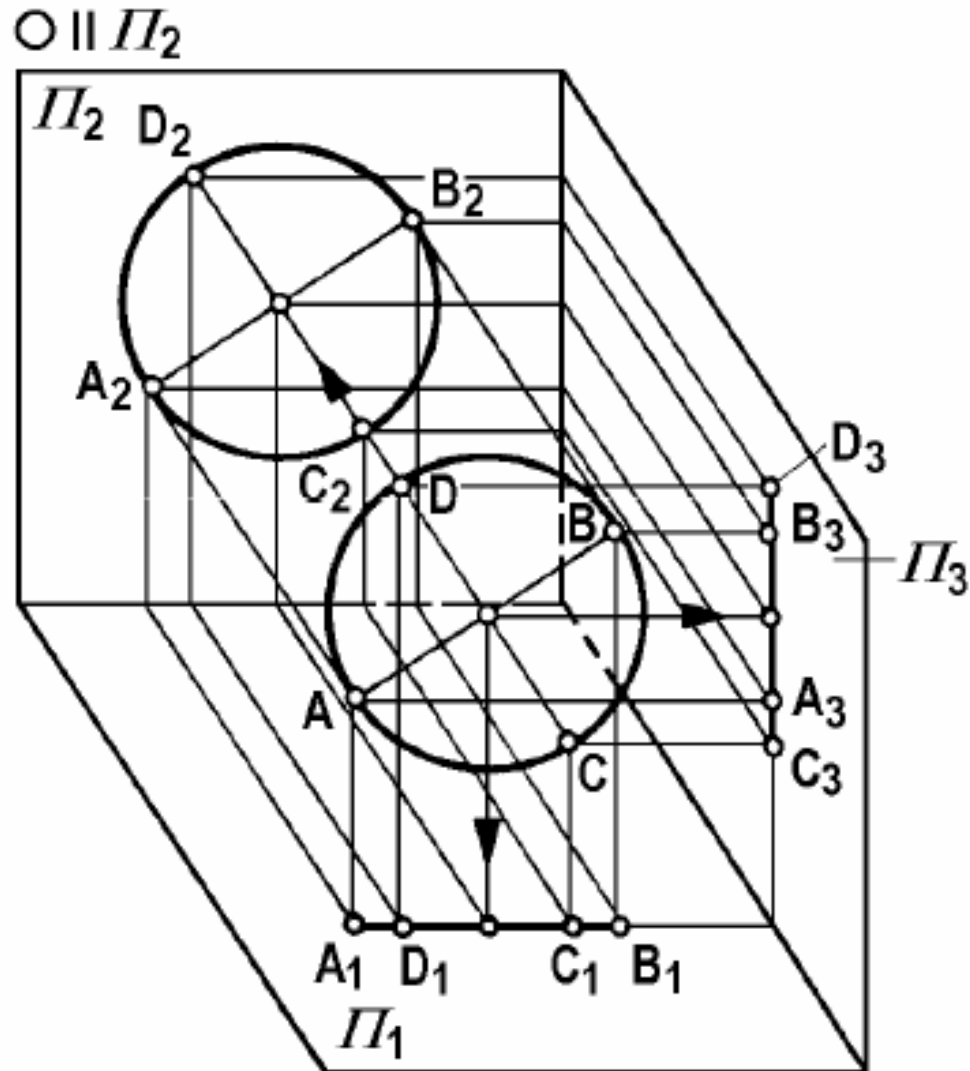
b)



# Projekcija krožnice, ki je pravokotna na $\pi_2$

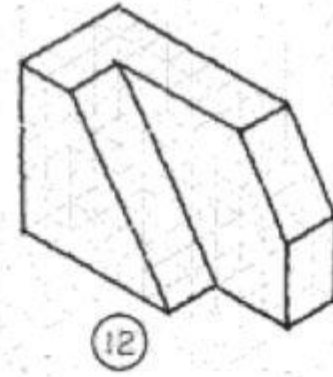
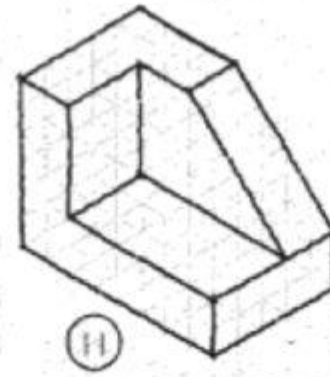
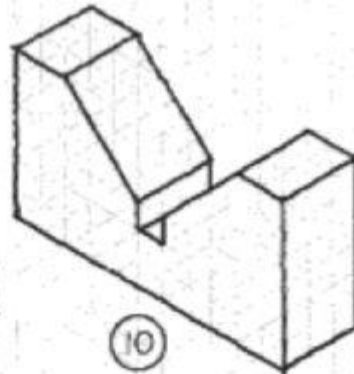
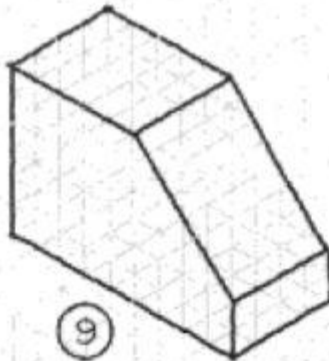
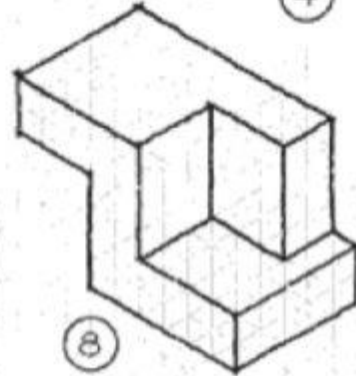
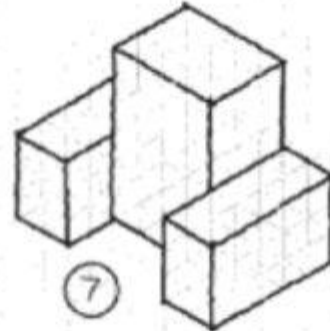
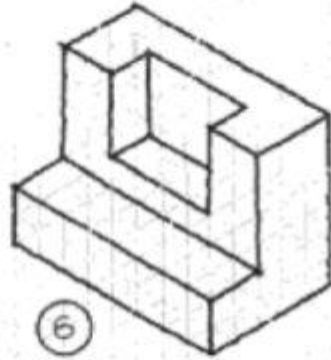
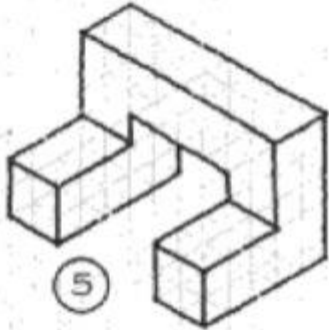
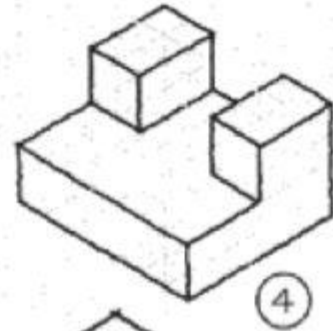
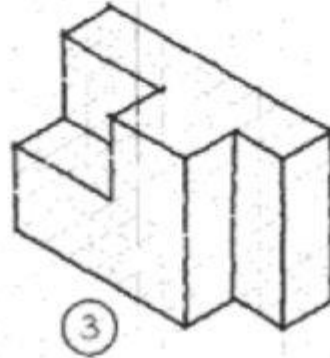
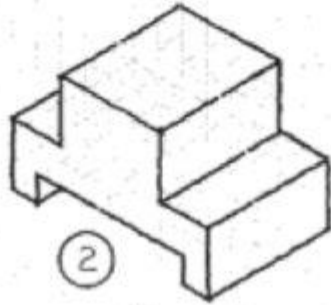
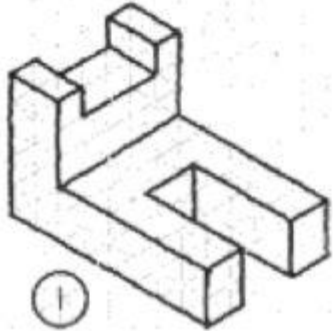


# Projekcija krožnice, ki je vzporedna na $\pi_2$

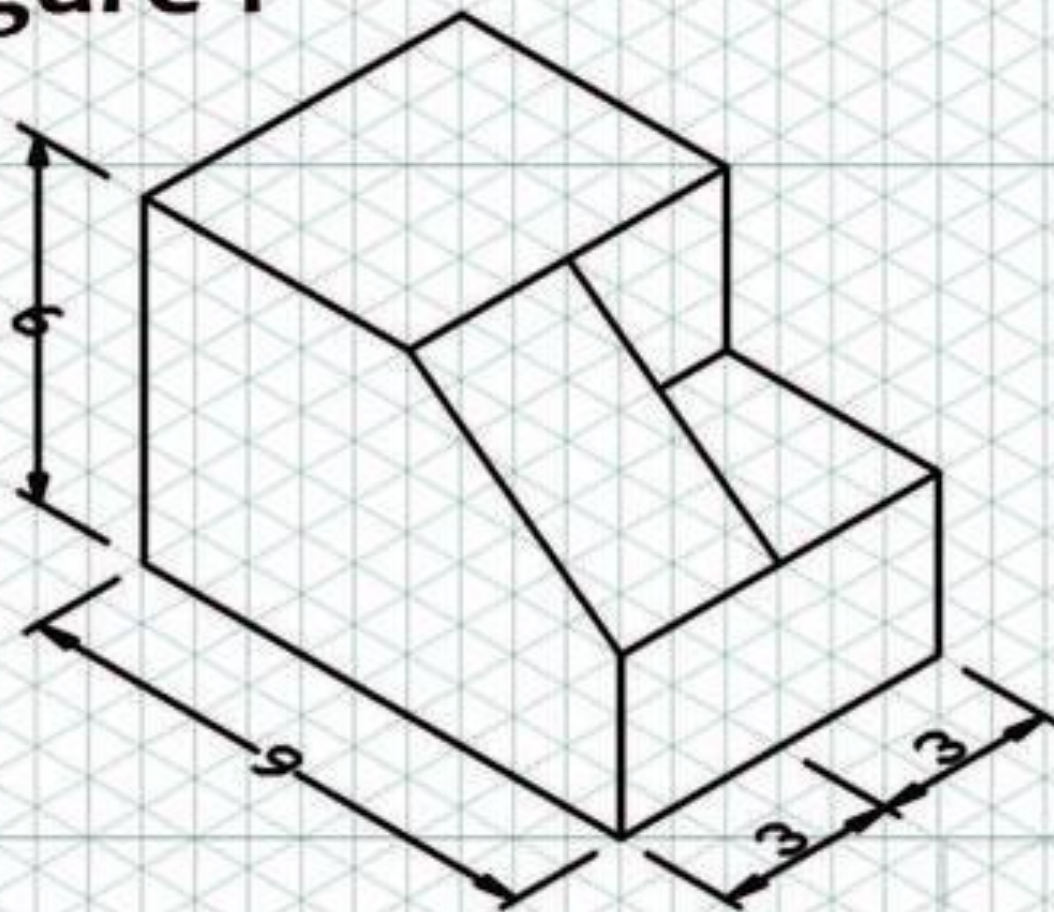








**Figure 1**



**Figure 2**

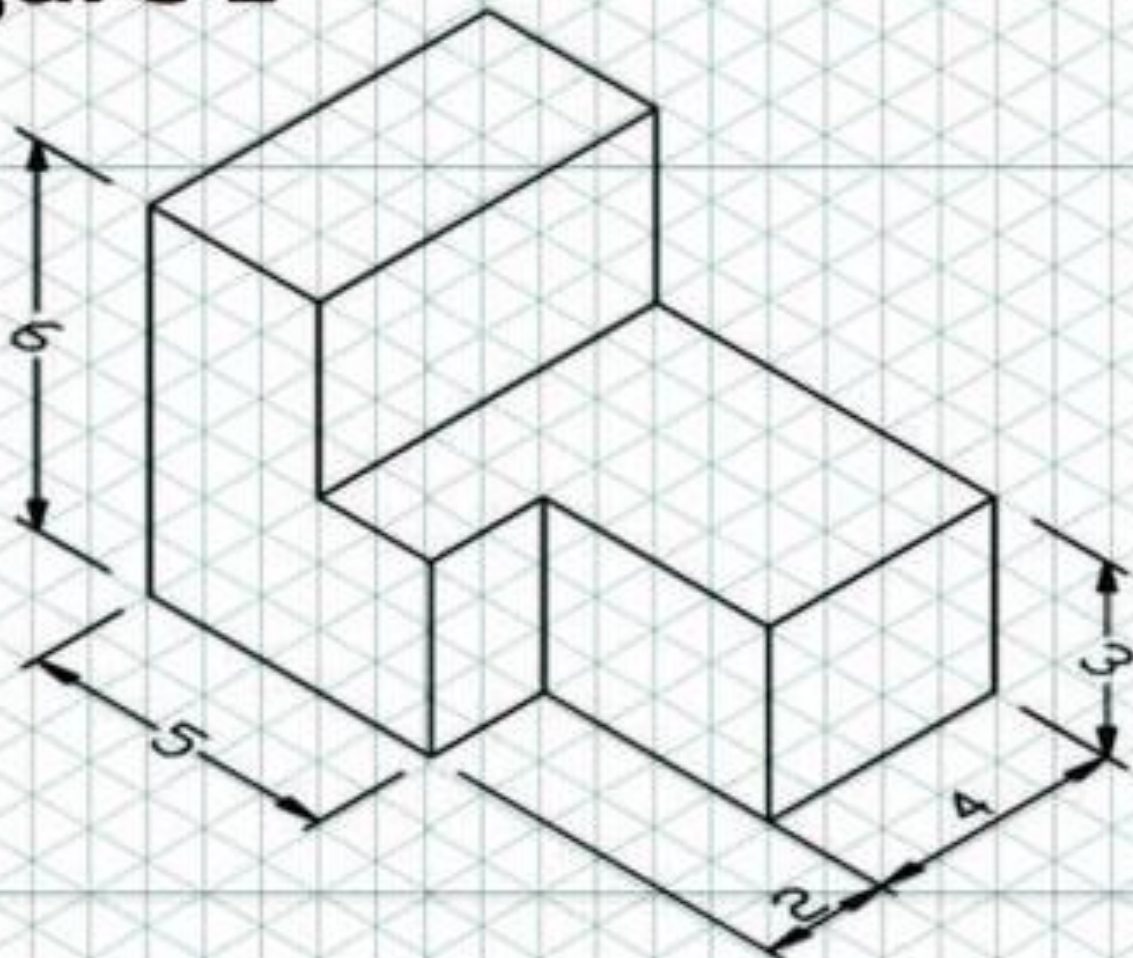
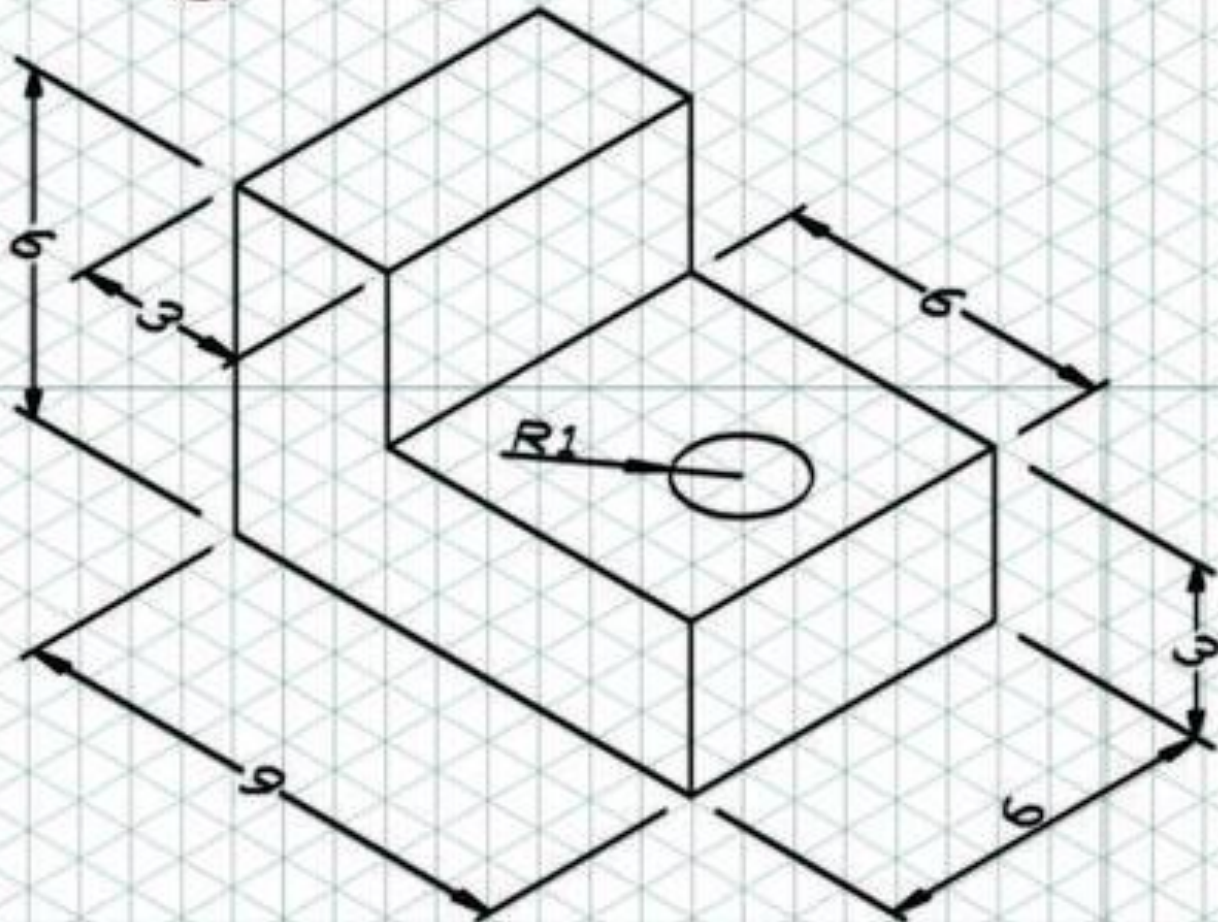
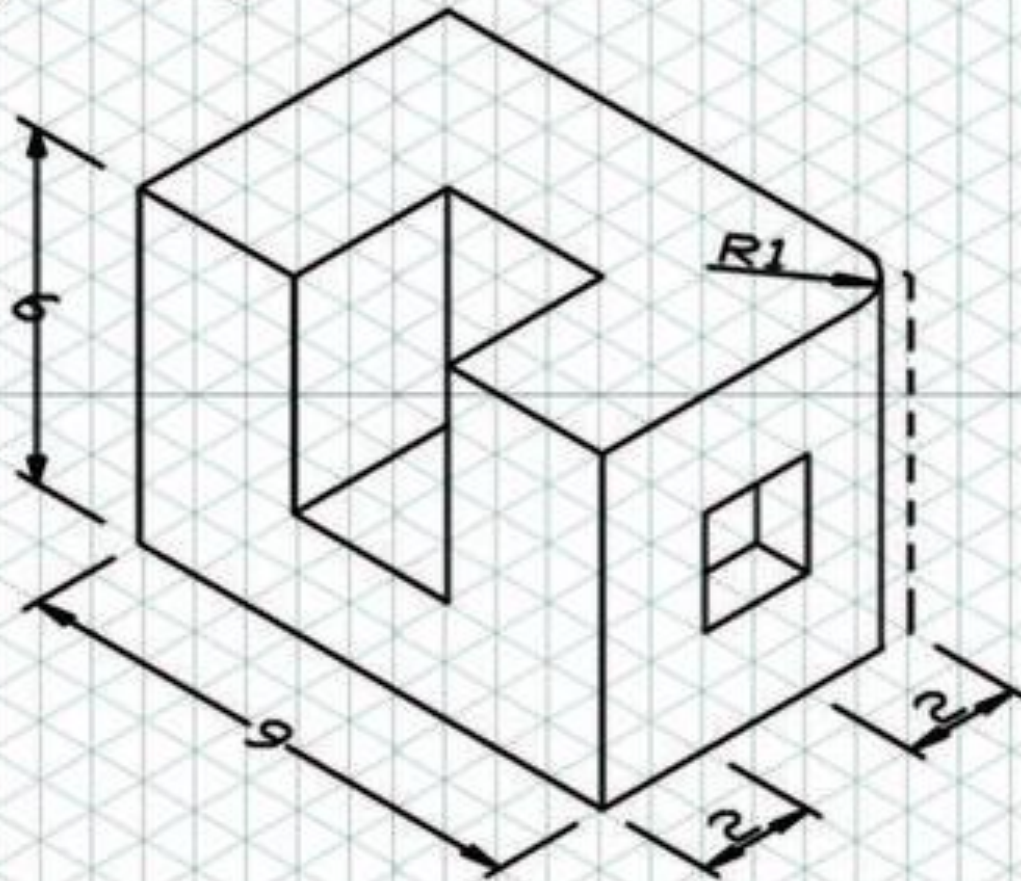
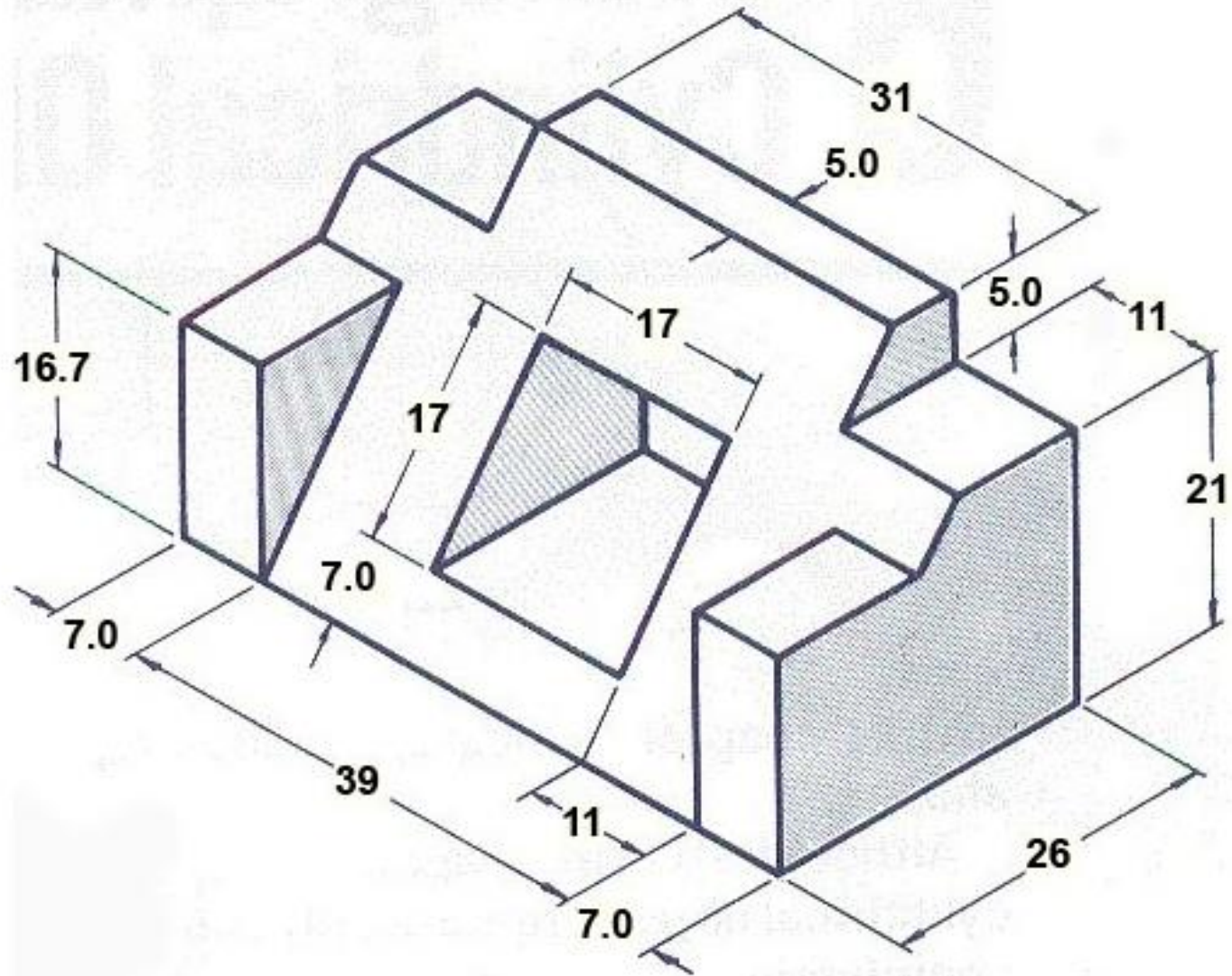


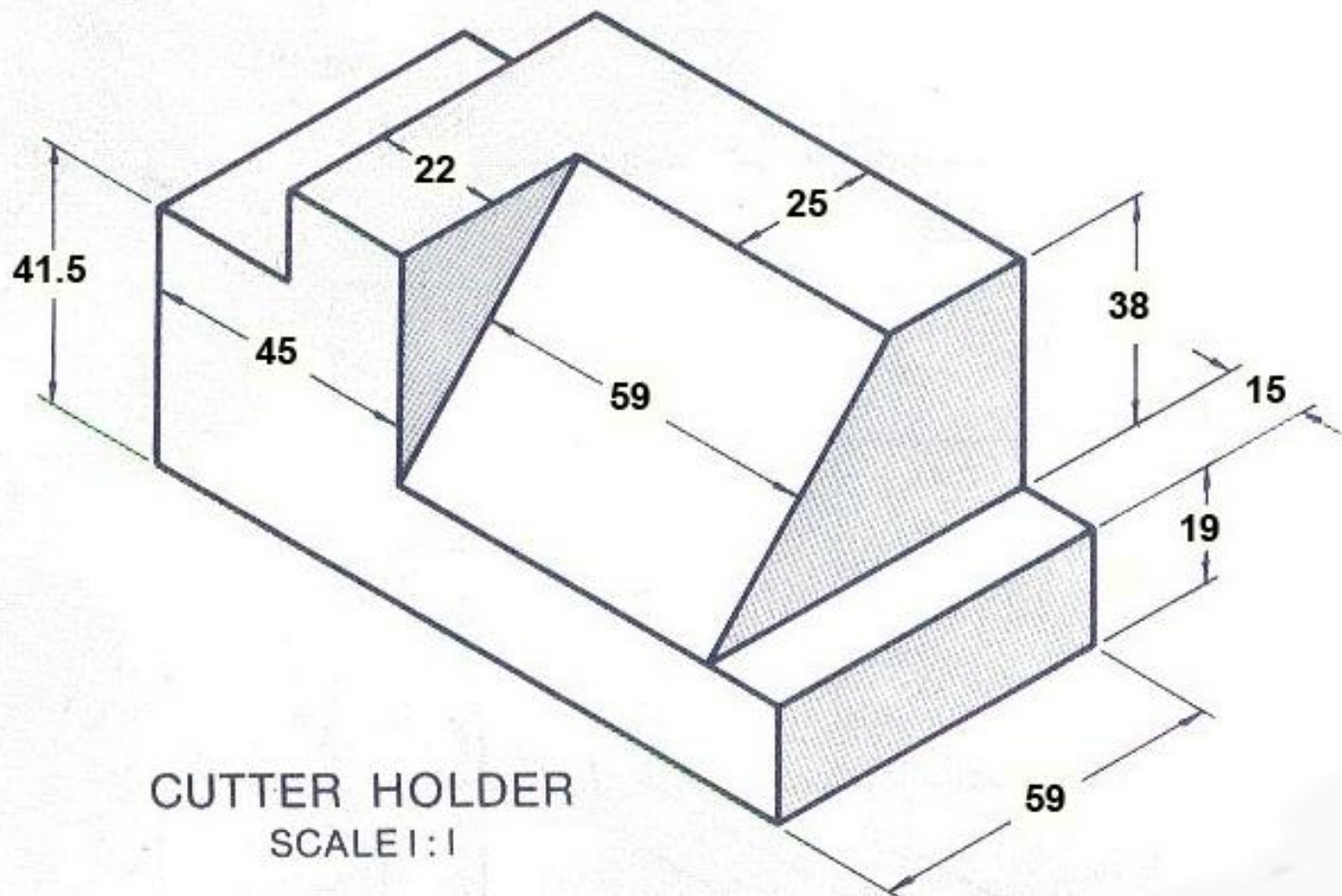
Figure 3



**Figure 4**



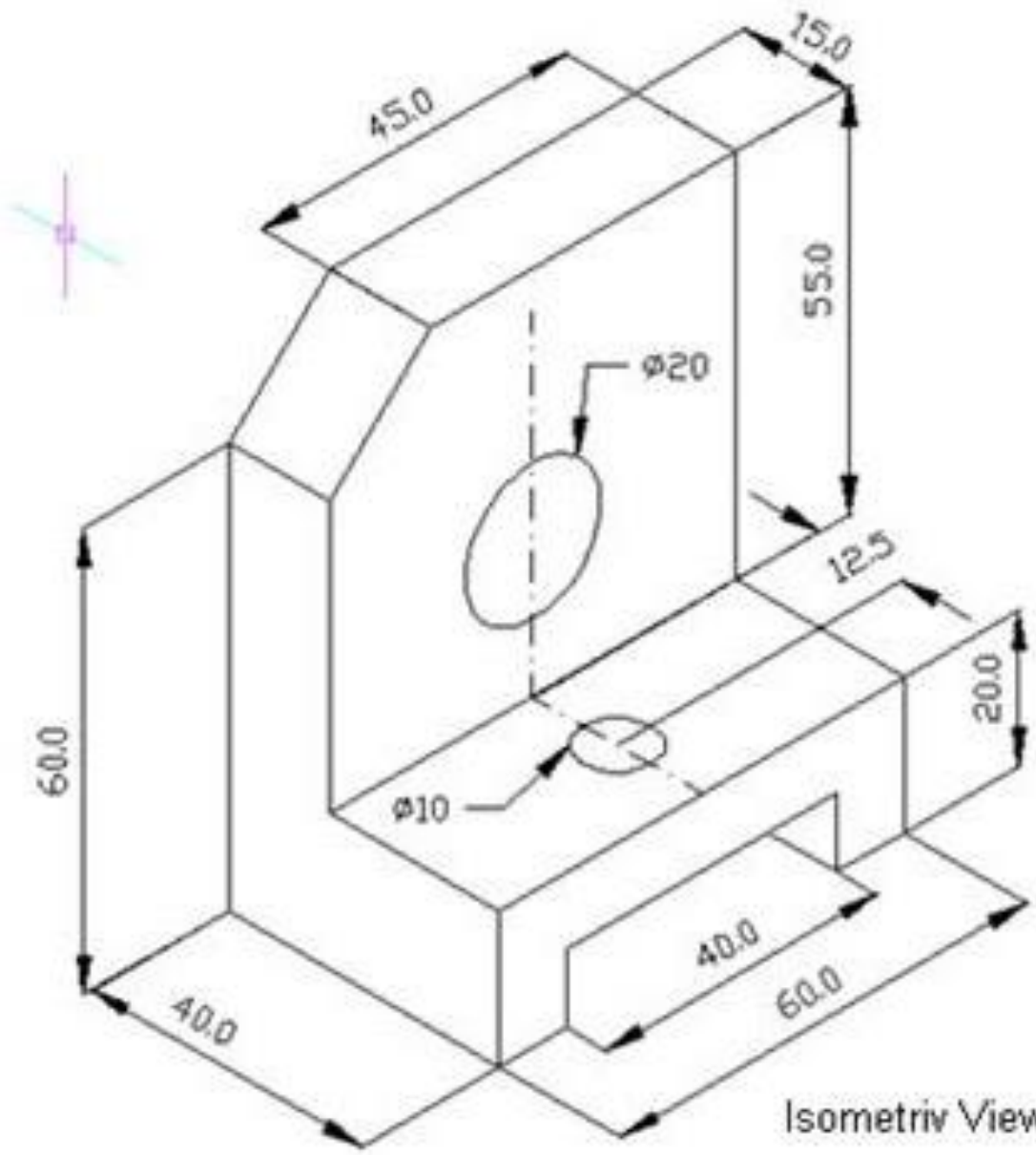




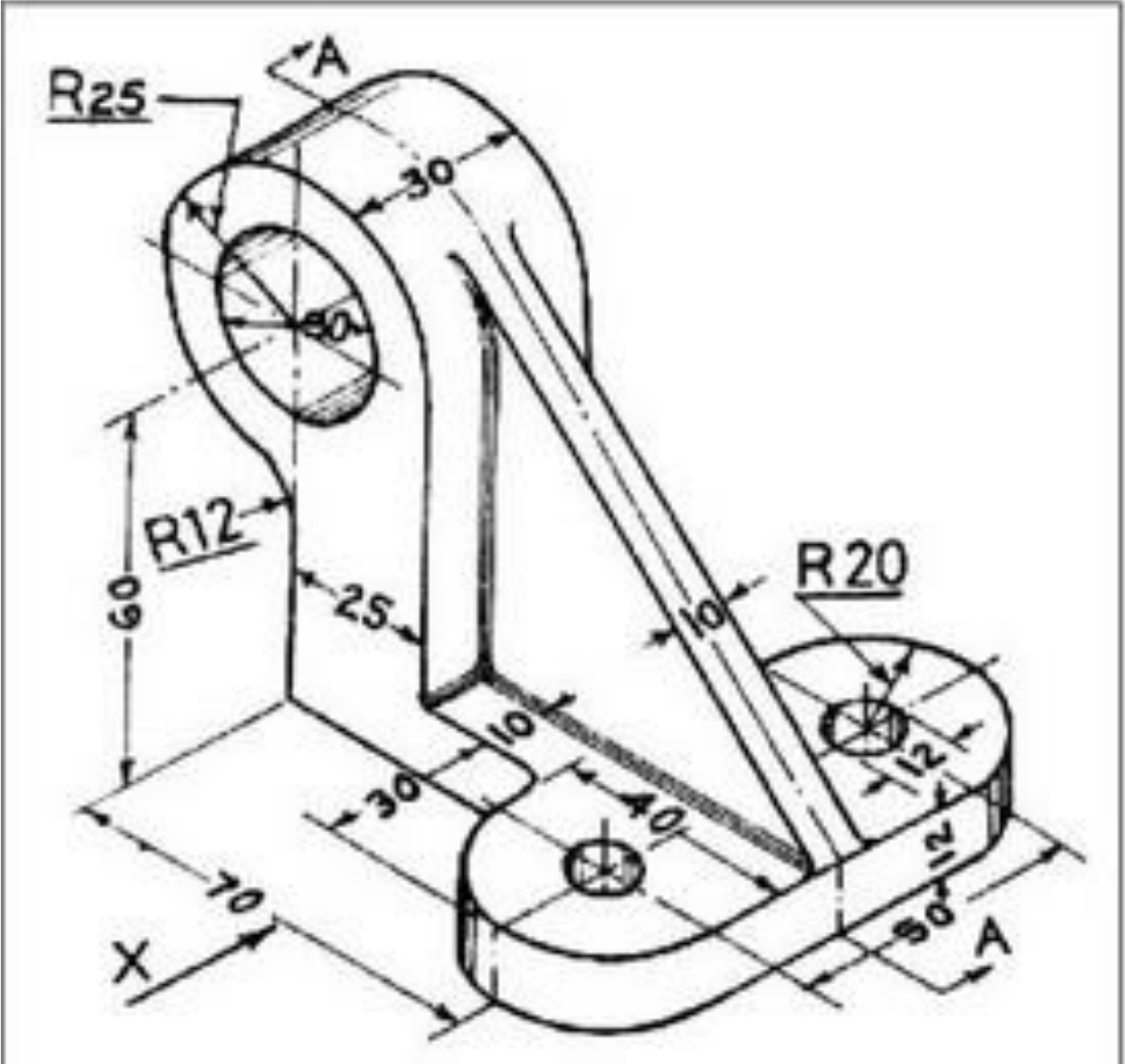
CUTTER HOLDER  
SCALE 1:1

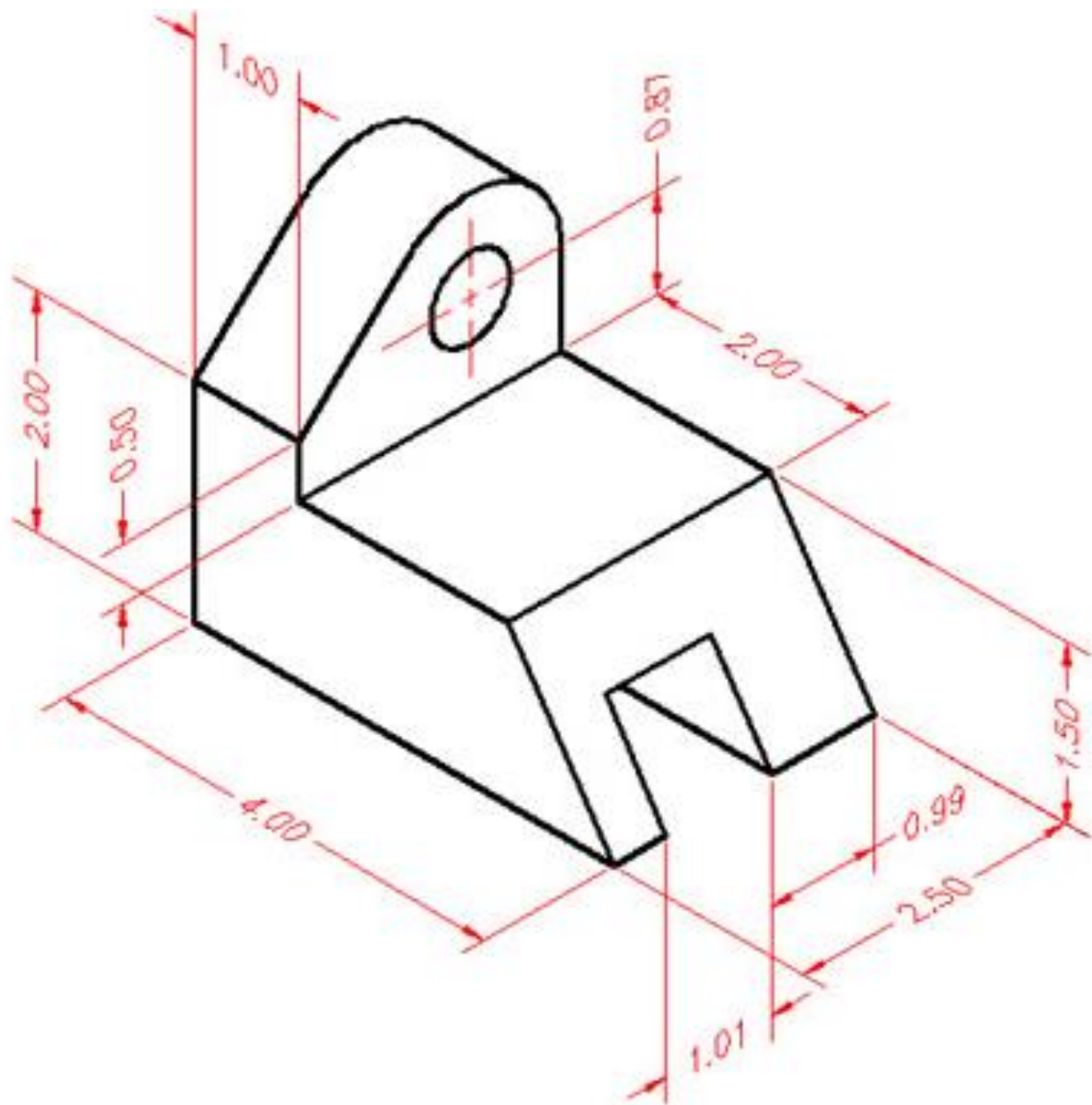
greencab

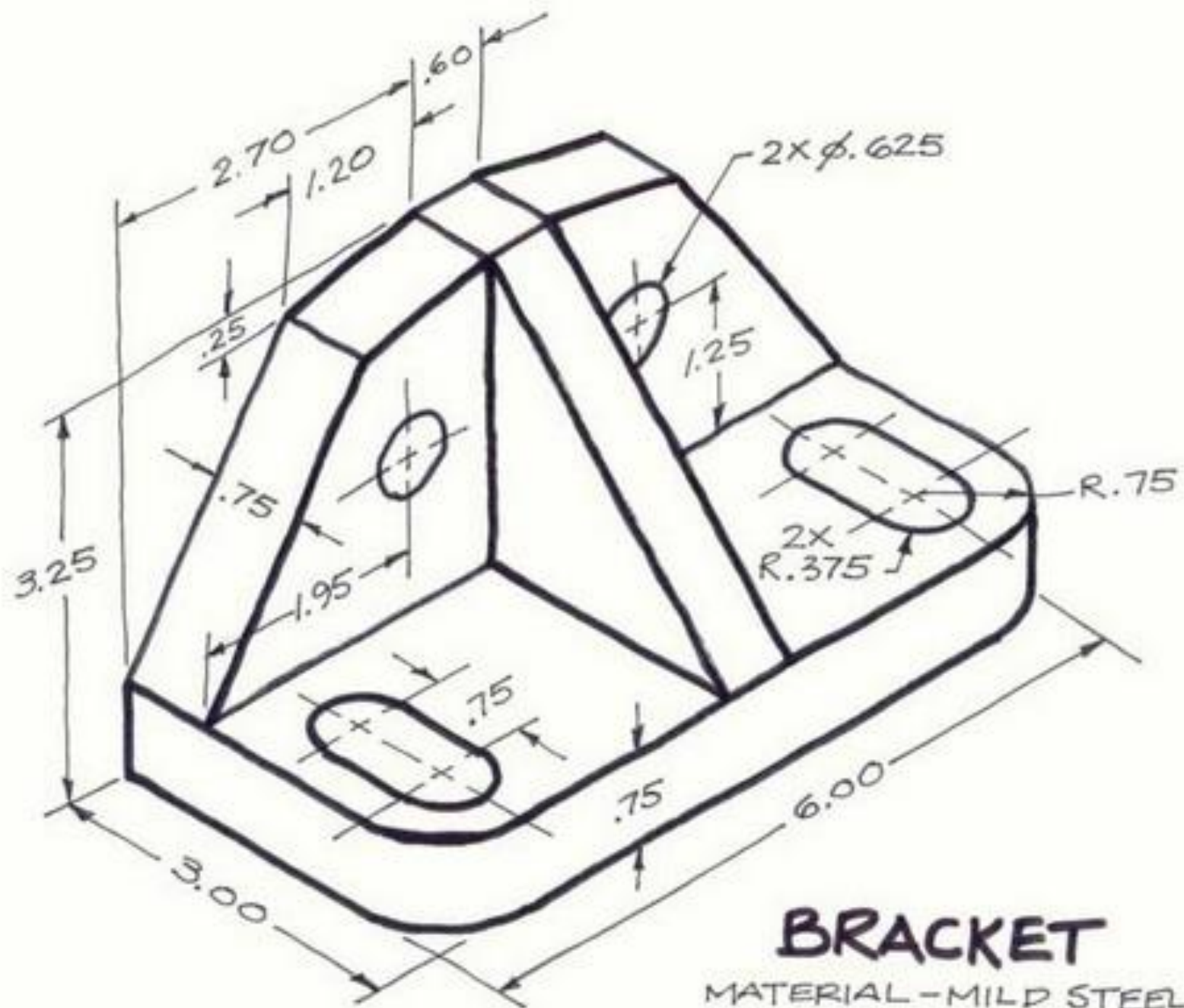




Isometric View







**BRACKET**  
MATERIAL - MILD STEEL

